**Steel and iron — Sampling and preparation
of samples for the determination of chemical
composition**

*Fontes et aciers — Prélèvement et préparation des échantillons pour
la détermination de la composition chimique*

This material is reproduced from ISO documents under International Organization for Standardization (ISO) Copyright License number IHS/ICC/1996. Not for resale. No part of these ISO documents may be reproduced in any form, electronic retrieval system or otherwise, except as allowed in the copyright law of the country of use, or with the prior written consent of ISO (Case postale 56, 1211 Geneva 20, Switzerland, Fax +41 22 734 10 78), IHS or the ISO Licensor's members.



Reference number
ISO 14284:1996(E)

Contents		Page
1	Scope	1
2	Normative references	1
3	Definitions	1
4	Requirements for sampling and sample preparation	2
4.1	General	2
4.2	Sample	2
4.3	Selection of a sample	4
4.4	Preparation of a sample	5
4.5	Safety precautions	7
5	Liquid iron for steelmaking and pig-iron production	7
5.1	General	7
5.2	Spoon sampling	7
5.3	Probe sampling	8
5.4	Preparation of a sample for analysis	8
6	Liquid iron for cast iron production	8
6.1	General	8
6.2	Spoon sampling	9
6.3	Probe sampling	10
6.4	Preparation of a sample for analysis	11
6.5	Sampling and sample preparation for the determination of oxygen, nitrogen and hydrogen	12

© ISO 1996

All rights reserved. Unless otherwise specified, no part of this publication may be reproduced or utilized in any form or by any means, electronic or mechanical, including photocopying and microfilm, without permission in writing from the publisher.

International Organization for Standardization
Case Postale 56 • CH-1211 Genève 20 • Switzerland

Printed in Switzerland

7	Liquid steel for steel production	12
7.1	General	12
7.2	Spoon sampling	12
7.3	Probe sampling	13
7.4	Preparation of a sample for analysis	13
7.5	Sampling and sample preparation for the determination of oxygen	14
7.6	Sampling and sample preparation for the determination of hydrogen	14
8	Pig-irons	15
8.1	General	15
8.2	Increment sampling	15
8.3	Preparation of a sample for analysis	16
9	Cast-iron products	17
9.1	General	17
9.2	Sampling and sample preparation	18
10	Steel products	19
10.1	General	19
10.2	Selection of a preliminary sample or a sample for analysis from a cast product	19
10.3	Selection of a preliminary sample or a sample for analysis from a wrought product	19
10.4	Preparation of a sample for analysis	21
10.5	Sampling of leaded steel	22
10.6	Sampling and sample preparation for the determination of oxygen	22
10.7	Sampling and sample preparation for the determination of hydrogen	22
Annexes		
A	Sampling probes for use with liquid iron and steel	24
B	Sampling probes for use with liquid steel for the determination of hydrogen	29

Foreword

ISO (the International Organization for Standardization) is a worldwide federation of national standards bodies (ISO member bodies). The work of preparing International Standards is normally carried out through ISO technical committees. Each member body interested in a subject for which a technical committee has been established has the right to be represented on that committee. International organizations, governmental and non-governmental, in liaison with ISO, also take part in the work. ISO collaborates closely with the International Electrotechnical Commission (IEC) on all matters of electrotechnical standardization.

Draft International Standards adopted by the technical committees are circulated to the member bodies for voting. Publication as an International Standard requires approval by at least 75 % of the member bodies casting a vote.

International Standard ISO 14284 was prepared by Technical Committee ISO/TC 17, *Steel*, Subcommittee SC 1, *Methods of determination of chemical composition*.

It cancels and replaces ISO 377-2:1989, of which it constitutes a technical revision.

Annexes A and B of this International Standard are for information only.

Steel and iron — Sampling and preparation of samples for the determination of chemical composition

1 Scope

This International Standard specifies methods for sampling and sample preparation for the determination of the chemical composition of pig iron, cast iron and steel. Methods are specified for use with both liquid and solid metal.

2 Normative references

The following standards contain provisions which, through reference in this International Standard, at the time of publication, the editions indicated were valid. All standards are subject to revision, and parties to agreements based on this International Standard are encouraged to investigate the possibility of applying the most recent editions of the standards indicated below. Members of IEC and ISO maintain registers of currently valid International Standards.

ISO 377:—¹⁾, *Steel and steel products — Location of samples and test pieces for mechanical testing*.

ISO 9147:1987, *Pig-irons — Definition and classification*.

3 Definitions

For the purposes of this International Standard, the following definitions apply.

3.1 chemical method of analysis: Method for the determination of chemical composition in which the sample is submitted to chemical reaction.

3.2 physical method of analysis: Method for the determination of chemical composition in which the determination of composition is carried out without submitting the sample to chemical reaction, for example an optical emission spectrometric method, an X-ray fluorescence spectrometric method.

3.3 thermal method of analysis: Method for the determination of chemical composition in which the sample is submitted to a process of heating, combustion or fusion.

3.4 melt: Liquid metal from which a sample is removed.

3.5 spoon sampling: Method in which the sample is taken from the melt, or during the pouring of the melt, using a long-handled spoon, and cast into a small mould.

3.6 spoon sample: Sample taken from the melt using a spoon and cast into a small mould.

3.7 probe sampling: Method in which the sample is taken from the melt using a commercially available sampling probe inserted into the melt.

3.8 immersion sampling: Method of probe sampling in which the probe is immersed in the melt where the sample chamber in the probe fills by ferrostatic pressure or gravity.

3.9 suction sampling: Method of probe sampling in which the probe is immersed in the melt where the sample chamber in the probe fills by aspiration.

¹⁾ To be published. (Revision of ISO 377-1:1989)

3.10 stream sampling: Method of probe sampling in which the probe is inserted into a stream of liquid metal where the sample chamber in the probe fills by the force of metal flow.

3.11 probe sample: Sample taken from the melt using a commercially available sampling probe.

3.12 cast product: Item of iron or steel which has not been subject to deformation, for example, an ingot, a semi-finished product obtained by continuous casting, a shaped casting.

3.13 wrought product: Item of steel which has been subject to deformation by rolling, drawing, forging or some other method, for example, a bar, a billet, a plate, a strip, a tube, a wire.

3.14 sample product: Specific item of iron or steel selected from a supplied quantity for the purpose of obtaining a sample.

3.15 preliminary sample: Sufficient quantity of metal selected from the sample product for the purpose of obtaining one or more samples for analysis.

3.16 sample for analysis: Part of the sample product, or part of the preliminary sample taken from the sample product, or part of the sample taken from the melt, brought to a required condition for submission to analysis.

The sample for analysis may comprise the sample product itself or the sample taken from the melt.

NOTE 1 The following categories of sample for analysis are distinguished:

- sample in the form of a solid mass;
- sample that has been remelted;
- sample in the form of chips obtained by machining;
- sample in the form of fragments obtained by comminution;
- sample in the form of powder obtained by comminution.

3.17 test portion: Part of the sample for analysis, or part of the sample taken from the melt, actually submitted to analysis. In certain cases, the test portion may be selected from the sample product itself.

NOTES

2 The following special types of test portions in the form of a solid mass obtained from a probe sample are distinguished:

- test portion in the shape of a small disc, commonly described as a slug, obtained by punching;
- test portion in the form of a small appendage, commonly described as a lug;
- test portion in the form of a small-diameter rod, commonly described as a pin, obtained by cutting.

3 When the sample for analysis is in the form of chips or powder, or when a sample in the form of a solid mass is analysed by a thermal method, the test portion is obtained by weighing. In the case of a physical method of analysis, the part actually analysed will constitute only a small mass of the sample for analysis. In an optical emission spectrometric method, the mass of metal consumed in an electrical discharge is about 0,5 mg to 1 mg; in an X-ray fluorescence spectrometric method, the characteristic radiation is produced from a very thin surface layer of the sample.

3.18 grinding: Method of preparing a sample of metal for a physical method of analysis in which the surface of the sample for analysis is abraded using an abrasive wheel.

3.19 finishing: Method of preparing a sample of metal for a physical method of analysis in which the surface of the sample for analysis is abraded using a flexible rotating disc or continuous belt coated with an abrasive substance.

3.20 milling: Method of preparing sample chips or the surface of a sample for a physical method of analysis in which the surface of the sample is machined using a rotating, multi-edged cutting tool.

3.21 consignment: Quantity of metal delivered at one time.

3.22 increment: Quantity of metal obtained by sampling at one time from a consignment.

4 Requirements for sampling and sample preparation

4.1 General

This clause covers the general requirements for the sample, and for the sampling and sample preparation of iron and steel. Special requirements apply to each category of liquid and solid metal and these are considered in the relevant subclause.

The sequence of sampling and sample preparation of liquid iron and steel, and cast iron and steel products is shown in figure 1. Special considerations apply to pig irons (see clause 8).

4.2 Sample

4.2.1 Quality

Sampling practices shall be designed to provide a sample for analysis that is representative of the mean chemical composition of the melt or the sample product.

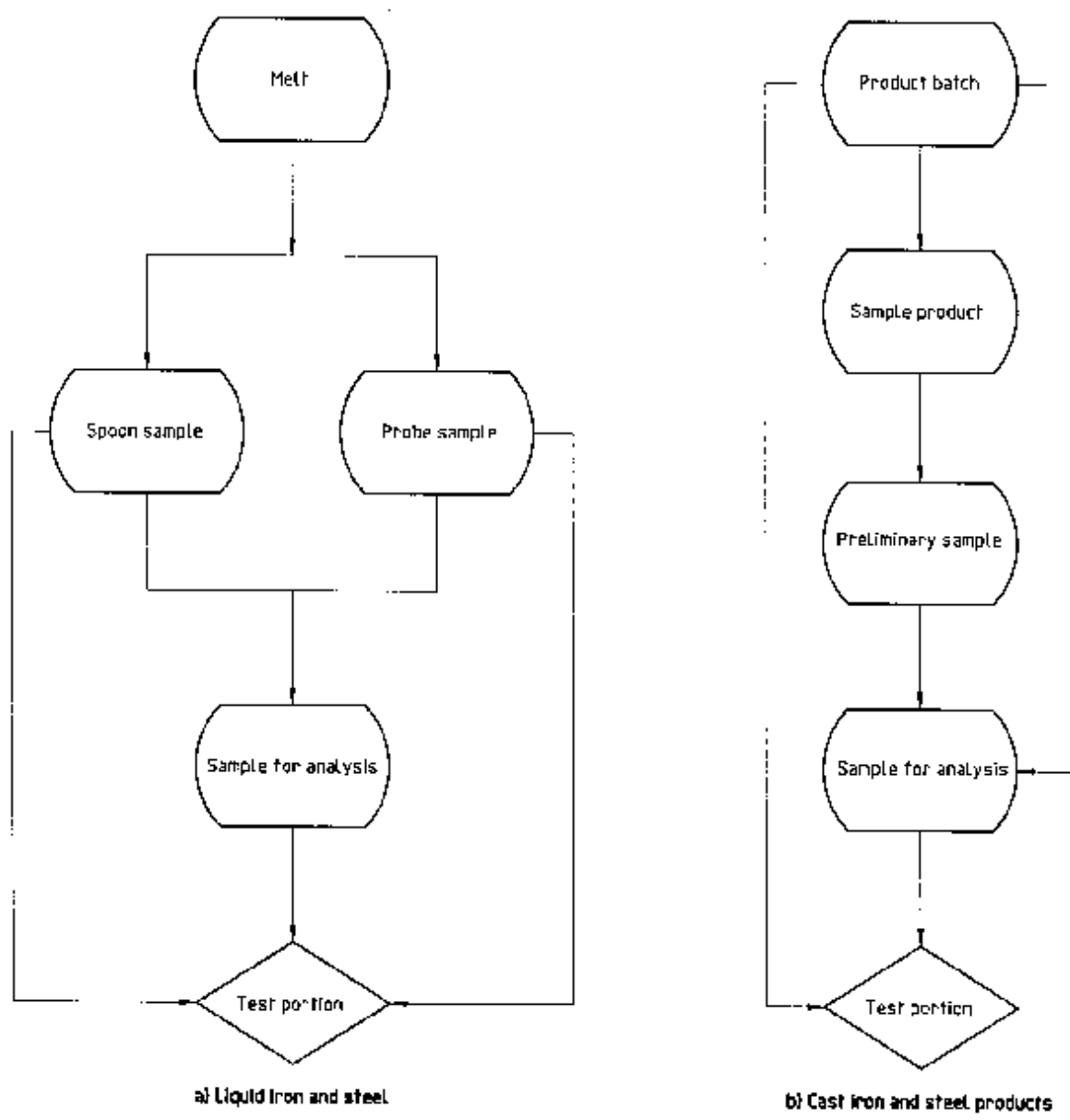

Figure 1 — Sequence of sampling and sample preparation

The sample for analysis shall be sufficiently homogeneous with respect to chemical composition such that inhomogeneity does not appreciably contribute to the error variability of the method of analysis. However, in the case of a sample taken from a melt, some variability in analysis, both within and between samples for analysis, may be unavoidable; this variability will form an inherent part of the repeatability and reproducibility of the analysis.

The sample for analysis shall be free from surface coatings, and from moisture, dirt or other forms of contamination.

As far as possible, the sample for analysis should be free from voids, cracks and porosity, and from fins, laps or other surface defects.

Particular care shall be taken when selecting and preparing the sample for analysis, where a sample taken from a melt is expected to be heterogeneous or contaminated in any way.

A sample taken from a melt shall be cooled in such a manner that the chemical composition and metallurgical structure of the sample is consistent from sample to sample.

It is important to recognize that analysis by some physical methods may be influenced by the metallurgical structure of the sample, particularly in the case of irons with white and grey iron structures, and in the case of steels in the as-cast and wrought conditions.

4.2.2 Size

The dimensions of a preliminary sample in the form of a solid mass shall be sufficient to permit additional samples for analysis to be taken for re-analysis, where necessary using an alternative method of analysis.

A sample for analysis, of a sufficient mass to provide for any re-analysis necessary, shall be prepared. Generally, a mass of 100 g will be sufficient for a sample in the form of chips or powder.

The dimensional requirements for a sample for analysis in the form of a solid mass will depend upon the method selected for analysis. In the case of optical emission and X-ray fluorescence spectrometric methods, the shape and size of the sample will be determined by the dimensions of the sample chamber. The dimensions for samples for analysis given in this International Standard should be regarded as indicative only.

4.2.3 Identification

A sample for analysis shall be assigned a unique identification in order to determine the melt of sample product from which it was taken and, if necessary, the processing conditions of the melt or the location of the preliminary sample or the sample for analysis in the sample product.

A sample for analysis of pig iron shall be assigned a unique identification in order to determine the consignment or part of a consignment and the increment from which it was taken.

Labelling or some equivalent method of marking shall be used to ensure that the assigned identification remains associated with the sample for analysis.

The identification, status and condition of the sample shall be recorded to ensure that confusion cannot arise as to the identity of the item to which analysis and records refer.

4.2.4 Conservation

Adequate storage facilities shall be provided to segregate and protect the sample for analysis. During and after preparation, the sample for analysis shall be stored in such a way as to prevent contamination or chemical change.

It is permitted to conserve the preliminary sample in the form of a solid mass, and a sample for analysis may then be prepared when required.

The sample for analysis, or the preliminary sample in the form of a solid mass, shall be kept for a sufficient period of time to protect the integrity of the test laboratory.

4.2.5 Arbitration

In the case of a sample intended for arbitration, the sample for analysis shall be prepared jointly by the supplier and purchaser, or by their representatives. A record shall be kept of the methods used for preparing the sample for analysis.

Containers with samples for analysis intended for arbitration shall be sealed by both parties or by their representatives. Unless agreed to the contrary, these containers shall be kept by the representatives of each party responsible for the preparation of samples.

4.3 Selection of a sample

4.3.1 Sample from a melt

Melts are sampled at various stages in the manufacturing process for the purposes of monitoring and controlling the process. Samples can be taken during the casting of the melt to verify chemical composition in accordance with the specification of the cast product. In the case of liquid metal intended for the production of a casting, the sample for analysis may be selected from test bars or blocks specially cast from the same metal as that of the casting for purposes of mechanical testing, in accordance with the product standard.

Sampling practices for melts shall be designed to provide samples during a particular manufacturing process in accordance with requirements for sample quality (see 4.2.1). The sample obtained from a melt is usually in the form of a small ingot, a cylindrical or rectangular block, a chill-cast disc or a combination of a disc with one or more attached pins; in some cases small lugs are attached to a disc sample.

NOTE 4 Sampling probes for use with liquid iron and steel may be obtained from a number of suppliers; the main features of the different types of probe are distinguished in annexes A and B, which include dimensions for information only.

4.3.2 Sample from a product

The preliminary sample or the sample for analysis can be selected from the sample product at the location indicated in the product specification for the selection of material for mechanical testing, when available.

In the case of an iron casting, the sample for analysis can be selected from a bar or block cast onto the casting.

In the case of a forging, the sample for analysis can be selected from the initial starting material from which the forging has been made, or from prolongations of the forging or from additional forgings.

In the absence of requirements given in the product standard, or of a specification when ordering the

product, the sample for analysis may, following agreement between the supplier and the purchaser, be selected from the sample for mechanical testing or from the test piece, or directly from the sample product.

The preliminary sample or the sample for analysis can be obtained from the sample product by machining or by using a cutting torch. Special considerations apply in the case of sampling for the determination of certain elements.

4.4 Preparation of a sample

4.4.1 Preliminary preparation

If any part of the sample is liable to be non-representative in chemical composition, for example due to oxidation, it may be agreed, following an investigation to establish the nature and extent of any change in composition, to remove from the sample those parts that have changed. Following this operation, the sample shall then be protected from any change in composition.

If necessary, the surface of the metal shall be laid completely bare at the point of machining, by any suitable means, to remove any coating that has been applied during manufacture. If necessary, the surface of the metal shall be degreased by means of a suitable solvent, taken care to ensure that the manner of degreasing does not affect the correctness of analysis.

4.4.2 Sample for analysis in the form of chips

The sample for analysis shall consist of chips of a regular size and shape. These may be obtained by methods such as drilling, milling, turning or punching. The chips shall not be taken from a part of the sample that has been affected by the heat of a cutting torch.

The tools, machines and containers used during preparation of the sample shall be cleaned beforehand to prevent any contamination of the sample for analysis.

Machining shall be carried out in such a way that the chips are not subject to overheating, as indicated by a change in the colour (blueing or blackening) of the chips. Unavoidable coloration of chips obtained from some types of alloy steels, for example manganese and austenitic steels, can be minimized by selection of appropriate tools and cutting speeds.

Heat treatment may be required to soften the sample for machining.

The use of coolants during machining is only permitted in exceptional cases; after which the chips shall be cleaned by means of a suitable solvent which does not leave any deposit.

Chips shall be thoroughly mixed before weighing the test portion. For most purposes, it is satisfactory to mix the chips by rolling the container on a level surface and/or gently tumbling the container.

4.4.3 Sample for analysis in the form of a powder or fragments

Where drilling of the sample to obtain chips is impracticable, it shall be cut or broken into pieces. These pieces shall then be crushed using a percussion mortar or a vibratory grinding mill, also known as a disc mill or ring mill, to obtain a sample for analysis in the form of a powder, the whole of which passes through a sieve of a specified aperture size.

In some applications for the determination of carbon using a thermal method of analysis, the sample is crushed in a percussion mortar to obtain a sample for analysis in the form of fragments with a particle size range of approximately 1 mm to 2 mm.

Equipment used for comminution shall be constructed from material which does not alter the sample composition. Suitable tests may be necessary to show that the use of such equipment does not affect the composition of the sample for analysis in any way.

Comminution shall not be used for the preparation of samples of graphite-bearing irons.

The sieving operation shall be performed taking all precautions necessary to avoid contamination or loss of material. When sieving hard materials, care shall be taken to avoid damaging the fabric of the sieve.

The sample for analysis shall be homogenized before weighing the test portion. Powders can be homogenized by stirring.

CAUTION — Finely-divided metals of particle size less than approximately 150 µm can present a fire risk. Ensure that there is adequate ventilation during comminution.

4.4.4 Sample for analysis in the form of a solid mass

4.4.4.1 Selection of the sample for analysis

The sample for analysis shall be obtained by cutting, from the sample product or preliminary sample, a piece of size and shape suitable for the method of analysis. Samples shall be cut by sawing, abrasive cutting, shearing or punching.

In the absence of any indication in the product standard, analysis by a physical method shall be carried out on that part of the sample corresponding to a transverse section of the product, provided that the material has sufficient thickness.

4.4.4.2 Surface preparation of the sample for analysis

The sample for analysis shall be prepared to expose a surface suitable for the method of analysis. Preparation of a surface for analysis shall not be carried out on any part of a sample that has been affected by the heat of a cutting torch. The equipment used for sample preparation shall be designed to minimize overheating the sample and, where appropriate, shall incorporate systems of cooling.

Four main types of equipment used for surface preparation may be distinguished.

- a) A milling machine capable of removing a preselected depth of metal in a reproducible manner, for use with samples that are within a hardness range suitable for milling. The equipment should be able to be used, if required, with a sample taken from a melt where the sample is still hot.
- b) A grinding machine with a fixed, rotating or oscillating head capable of removing a preselected depth of metal in a reproducible manner.
- c) A flat-bed finishing machine with abrasive grinding discs, or a machine with continuous abrasive-belts, able to be used to prepare the surface of the sample for analysis to varying grades of finish.
- d) A machine for blasting with sand, grit, or metal shot, able to be used in special applications to clean the surface of the sample for analysis or the test portion.

After preparation, the surface of the sample for analysis shall be flat and free from defects which affect the correctness of analysis.

Cutting and surface preparation can be performed either manually or automatically. In the case of samples taken from melts, commercially available systems, which perform each stage of preparation automatically, may be used. Systems for the automatic preparation of surfaces of dual-thickness probe samples (see A.2.3 c) in annex A), and for the punching of slugs forming test portions, may incorporate facilities for the sand-blasting of the sample and for heat treatment to soften the sample before punching.

The abrasive substances used in the final stage of preparing the sample for analysis shall be selected so as to avoid contaminating the surface with elements that are to be determined by the analysis method. The grit size of the abrasive shall be in accordance with the grade of surface finish required for the analysis method.

In the case of optical emission spectrometric methods, an abrasive with a grade of 60 grit to 120 grit is normally suitable. In the case of X-ray fluorescence spectrometric methods, it is essential to ensure that the

method selected for surface preparation produces a grade of surface finish that is reproducible from sample to sample. In addition, there should be no smearing of the surface.

The effect of abrasive materials depends on the analytical method. When using optical emission spectrometric methods, the action of pre-sparking will normally clean the surface of the sample for analysis by volatilizing any grinding contaminants. However, particular care is required to avoid surface contamination when using a new abrasive disc.

When using X-ray fluorescence spectrometric methods, all the phases of surface preparation shall be examined for potential surface contamination effects.

The sample for analysis shall be examined visually after preparation to establish that the surface is free from particulate matter and that there are no defects; the sample shall be resurfaced or discarded if defects are present. The sample for analysis shall be dry and care shall be taken to protect the prepared surface from contamination.

4.4.5 Preparation of a sample for analysis by remelting

A sample in the form of small pieces or chips, or a part of the sample product itself, can be remelted in an atmosphere of argon using commercially available melting equipment. The sample is converted into a disc, 40 mm to 30 mm in diameter and 6 mm thick, which is suitable for analysis by a physical method. Some types of remelting equipment incorporate facilities for the centrifugal casting of the disc.

Partial losses of some elements can be experienced during the remelting process. It is essential to ensure that any selective volatilization or segregation of elements, or any other change in composition, which occurs is quantitatively known and does not significantly influence the analysis results. Suitable tests shall be carried out to show that any change in composition is both small in magnitude and reproducible.

The equipment used and the method adopted for remelting shall be designed to prevent or minimize a change in composition and to ensure that any change is reproducible. A deoxidant, for example 0,1 % (m/m) zirconium, should be used during remelting. The method used for calibration of the analytical measurement shall take account of any change that does occur.

Not all ferrous metals can be remelted in this manner. This method shall not be used for sample preparation for the determination of an element which is subject to a significant and non-reproducible change in composition, when remelted.

4.5 Safety precautions

4.5.1 Personal protection

Personal protective equipment shall be provided to minimize the risk of injury during sampling and sample preparation methods. Provisions shall include protective clothing, hand protection and face visors resistant to splashes, for use during the sampling of liquid metal. Provisions shall also include protective clothing, hand, eye and hearing protection, for use during the sampling and sample preparation of solid metal; and respiratory protection for use where necessary.

4.5.2 Machinery

The use of machinery for sampling and sample preparation shall be in accordance with appropriate national standards. Grinding operations used for surface preparation may be covered by national legislation.

4.5.3 Hazardous substances

Reference shall be made to appropriate national regulations with regard to the use of solvents for the cleaning and drying of samples and test portions.

5 Liquid iron for steelmaking and pig-iron production

5.1 General

The following methods are applicable to the sampling of liquid blast-furnace iron intended for steelmaking, and commonly described as hot metal, or for the casting of pig-iron. The liquid iron is normally sampled from the blast furnace runner while the melt is poured into torpedo ladles, or from transfer vessels, or during secondary treatment processes in the ladle, or during the casting of the melt into pig-iron.

The chemical composition of iron may fluctuate during run-out from the blast furnace. Two or more samples should be taken from the melt at timed intervals and an average analysis determined.

When physical methods are used for analysis, the method of sampling should be designed to chill the liquid metal in a manner which ensures that the metalurgical structure of the sample is suitable for the requirements of the analysis method selected.

5.2 Spoon sampling

5.2.1 Methods

For sampling from a melt, immerse a preheated steel spoon into the melt and fill with liquid iron. Withdraw the spoon and remove any slag by skimming the surface of the liquid iron in the spoon.

For sampling from a stream, introduce a preheated steel spoon into the stream from the ladle and fill it with liquid iron.

Pour the liquid iron from the spoon without delay into a metal mould to chill the iron as rapidly as possible. Remove the sample from the mould and break off any riser.

It is essential that the liquid iron should be poured into a mould that is cold to ensure adequate chilling; if necessary, the mould should be air-cooled before use. The mould shall be free from moisture.

A disc-shaped sample, commonly described as a coin sample, can be obtained using a two-piece steel mould; the sample is typically 35 mm to 40 mm in diameter with a thickness varying from 6 mm to 12 mm. The mould is constructed in two pieces which are clamped together while in use: one piece is a flat chill plate, the other is a block with the mould cavity. The edge of the mould cavity may be tapered, for example, from 38 mm to 32 mm, to facilitate removal of the sample from the mould. A coin sample is vertically or horizontally cast in the mould.

A coin sample with one or more attached pins can be obtained using a combination-type mould. The pins are broken off from the disc and used, if required, as test portions for analysis by a thermal method. (A combination-type mould for use with liquid iron intended for the production of cast iron is shown in figure 2.)

A thin slab-shaped sample with a rounded end can be obtained using a cast iron or steel split-mould; the dimensions of the sample are typically 70 mm x 35 mm with a thickness of 4 mm. The two halves of the mould are bevelled at the top to give a feeder head and are clamped together while in use. This type of mould may be preferred for use with liquid iron containing high percentages of carbon.

5.2.2 Maintenance of equipment

It is essential to keep sampling spoons and metal moulds clean and dry. After use, remove any slag and skull and clean the surfaces of the mould with a wire brush.

Moulds should be remachined if the internal surfaces become worn. This avoids the need for additional machining of the sample during surface preparation.

5.3 Probe sampling

5.3.1 General

The different types of probes used for sampling blast furnace iron are described in annex A. Probes should be designed to provide a disc-shaped sample with a white iron structure which is sufficiently deep for the requirements of the physical method selected for analysis.

Probe sampling is influenced by such factors as the angle and depth of immersion of the sampler in the melt, and immersion times can vary depending on the temperature of the liquid iron. These factors should be determined for the particular ironmaking practice and thereafter strictly controlled to maintain the standard of quality of the sample for analysis.

5.3.2 Methods

For sampling from a melt, immerse a suitable immersion probe sampler into the melt at an angle as near as possible to the vertical plane.

When sampling from the runner of a blast furnace, select the position of immersion to give a sufficient depth of liquid metal for the use of a probe sampler. A depth of approximately 200 mm is adequate for most types of sampling probe.

For sampling from a stream of liquid iron, introduce a suitable suction probe sampler into the metal flow from a ladle, at an angle of approximately 45° to the vertical plane, at a position as near as possible to the nozzle of the vessel.

Withdraw the probe sampler from the melt after a predetermined interval of time, break it apart and allow the sample to cool in air.

5.4 Preparation of a sample for analysis

5.4.1 Preliminary preparation

Remove any surface oxidation from a sample taken from the melt, that may contaminate the sample for analysis during subsequent preparation.

5.4.2 Sample for analysis by a chemical method

Break the sample into small pieces and crush pieces using a percussion mortar or a vibratory grinding mill to obtain a sufficient mass of sample for analysis of particle size preferably less than about 150 µm.

Alternatively, obtain chips by drilling the sample at a low speed as described in 8.3.1.

5.4.3 Sample for analysis by a thermal method

Break the pin of a disc-shaped sample into pieces of a suitable mass for use as test portions, or use the lugs of a probe sample. Analyse a representative number of test portions to obtain an average value.

Alternatively, crush the pin or lugs in a percussion mortar to obtain a sufficient mass of sample for analysis of particle size approximately 1 mm to 2 mm. Avoid the production of fine material during crushing. In the case of a slab-shaped sample, break the sample into small pieces and crush the pieces in a similar manner.

5.4.4 Sample for analysis by a physical method

In the case of a disc-shaped sample, remove any lugs or pins, as necessary, and then grind the surface of the sample to expose a white iron structure which is representative of the sample. The amount of material to be removed in this way shall be determined for the chemical composition of the particular iron and the conditions of sampling; the thickness of the layer to be removed normally lies between 0,5 mm and 1 mm (see A.6).

In the case of a slab-shaped sample, break the slab into two pieces to obtain a sample of suitable size for analysis.

Prepare the surface of the sample by grinding and finishing. Grinding shall be carried out wet to avoid overheating the sample but the final surface preparation shall be dry finishing. Alternatively, cool the sample after grinding by immersion in water and then finish by dry finishing.

Particular care is required when preparing the surface of thin samples. A chuck shall be specially designed to hold the sample securely grinding and finishing operations.

6 Liquid iron for cast iron production

6.1 General

The following methods are applicable to the sampling of liquid iron from cupola furnaces and electric furnaces, from holding furnaces in duplex processes, and from ladles and treatment vessels.

Liquid iron intended for the production of iron castings may be subject to inhomogeneity, and particular care is required in the design of strategies and methods of sampling to meet the requirements of the particular production process. For example, liquid iron in holding furnaces tends to stratify and sampling should ensure that the analysis is representative of the melt as a whole.

In batch processes, two or more samples should be taken from melting furnaces, preferably when approximately one-third and two-thirds of the melt has been discharged, and an average analysis determined. In continuous processes, samples should be taken at regular intervals of time.

Methods of sampling are normally designed to chill the liquid metal of a sample cast from a spoon as rapidly as possible to produce a metallurgical structure of white iron that is free from graphite. A white iron structure obtained by chill-casting is generally required for analysis by physical methods.

Non-chilled samples may also be used. In this case, samples can be specially cast from a spoon, or a sample for analysis can be selected from a test bar or reel block intended for mechanical testing. Test bars or blocks are cast separately from the same metal as that used to produce the casting or castings.

By agreement with the customer, when large castings or large numbers of castings are produced, two or more samples should be obtained.

Special considerations apply to the sampling and sample preparation of liquid iron for the determination of oxygen, nitrogen and hydrogen (see 6.5).

6.2 Spoon sampling

6.2.1 General

Sampling should take place before any additions of inoculating agents have been made to the melt.

Alternatively, sufficient time should be allowed to elapse for the immediate effect of the additions to have faded and the melt should be thoroughly stirred before sampling. Failure to allow adequate standing time before taking the sample will seriously impair the representativity of sampling.

Ductile iron is particularly difficult to sample due to the possibility of contamination by dross during the production process. In this case, a suitable sample may be obtained by filtering the iron using a ceramic disc.

NOTE 5 Where sampling takes place before addition of inoculating agents, it should be recognized that the sample obtained will not be representative of the chemical composition of the cast product.

6.2.2 Methods

A graphite spoon or a steel spoon lined with a layer of a refractory such as ganister is suitable for use in accordance with one of the following methods.

- a) Remove any slag from the surface of the melt by skimming and then immerse a preheated spoon into the melt and fill with liquid iron.

- b) Introduce a preheated spoon into the stream during pouring and fill with liquid iron.

6.2.3 Chilled sample

Pour the liquid iron from the spoon without delay into a split mould made from graphite, haematite iron or copper to obtain a sample in the form of a small, flat plate, 4 mm to 8 mm in thickness. Remove the sample from the mould as soon as it is solid to avoid overheating the mould and the risk of breakage of the sample, then break off any riser.

The sample, commonly described as a coin sample, may be circular, rectangular or square in shape with typical sizes respectively 35 mm to 40 mm diameter, 50 mm x 27 mm and 50 mm x 50 mm. Generally, disc samples are vertically cast and rectangular and square samples are horizontally cast.

The mould is constructed in two pieces which are clamped together while in use: one piece is a flat chill-plate, the other is a block with the mould cavity. The edge of the mould cavity may be tapered to facilitate removal of the sample from the mould.

A coin sample with one or more attached pins can be obtained using a combination-type mould. The pins are broken off from the disc and used, if required, as test portions for analysis by a thermal method. A vertical mould of this type, commonly described as a book mould and made from low-phosphorus, high-carbon grey iron, graphite, copper or water-cooled copper, is shown in figure 2. The sample obtained is a disc, 35 mm to 40 mm in diameter and 4 mm to 6 mm thick, with three 5 mm diameter pins.

The temperature of the liquid iron in the spoon shall be as high as possible and compatible with the mould material. It is essential that the mould be cold to ensure adequate chilling for the production of a sample for analysis with a white iron structure. If necessary, the mould should be air-cooled before use. The mould shall be free from moisture.

In the case of process where samples are required to be taken at frequent intervals, several moulds shall be provided to ensure that a cold mould is available for use.

Thermal stress due to overheating of the mould can cause breakage of the coin sample and shall be avoided.

6.2.4 Non-chilled sample

Pour the liquid iron from the spoon without delay into a sand mould to obtain a cylindrical block-shaped sample approximately 50 mm in diameter and 40 mm to 50 mm long.

Dimensions in millimetres

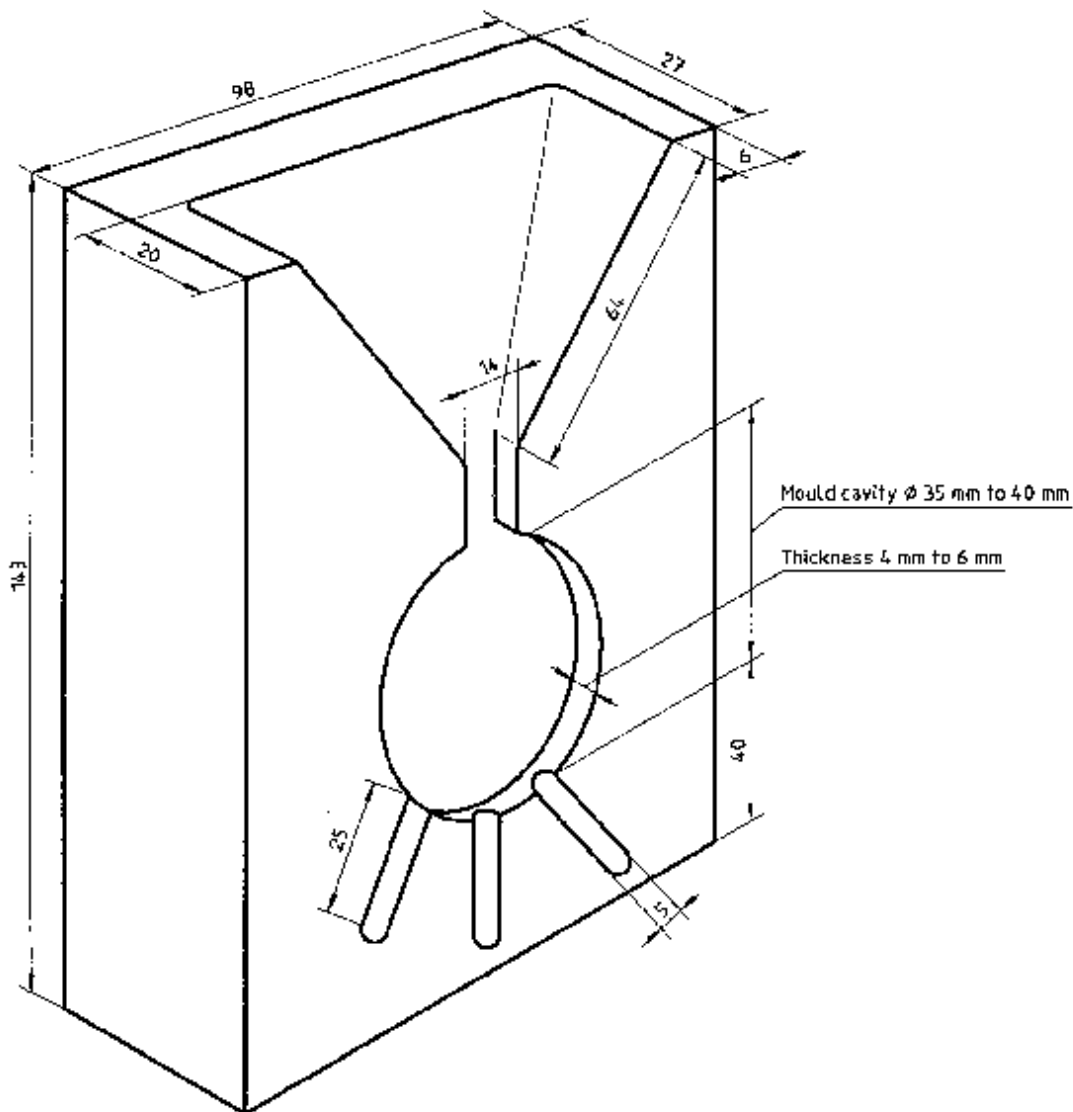

NOTE — The flat chill-plate (not shown) has similar overall dimensions.

Figure 2 — Combination-type vertical mould used for sampling liquid iron intended for cast iron production

Alternatively, a sample for analysis can be selected from a test bar or keel block intended for mechanical testing. Test bars or blocks are cast either from liquid iron taken from a ladle using a pouring spoon or, if a small hand-ladle is used for pouring, directly from the ladle itself. Bars are typically 30 mm in diameter and 150 mm long and may be vertically or horizontally cast in a sand mould.

Samples shall be allowed to cool completely before removal from the mould.

6.2.5 Maintenance of equipment

It is essential to keep pouring spoons and metal moulds clean and dry. After use, remove any slag and

skull and clear the surfaces of the mould with a wire brush.

Moulds should be remachined if the internal surfaces become worn. This avoids the need for additional machining of the sample during surface preparation.

6.3 Probe sampling

Probe sampling is used only to a limited extent in the manufacture of cast iron products. Sampling probes, if required, shall be designed to provide samples from the melt of a quality and metallurgical structure required by the analysis method.

6.4 Preparation of a sample for analysis

6.4.1 Preliminary preparation

Remove any sand adhering to the surface of a sand-cast sample by scratch-brushing or shot-blasting. Remove any surface oxidation by grinding.

Prepare the sample in accordance with one of the procedures described in 6.4.2, 6.4.3 or 6.4.4, depending upon the method selected for analysis.

6.4.2 Sample for analysis by a chemical method

6.4.2.1 General

Machining to obtain chips should be carried out by drilling or turning at a low speed (100 r/min to 150 r/min) using a tungsten-carbide tipped tool, adjusting the speed and feed to produce chips of uniform size while avoiding the production of fine particles. Care shall be taken to avoid overheating both the sample and the tool.

Chips should be as solid and compact as possible, with a mass of approximately 10 mg (100 chips per gram) in order to prevent crumbling and loss of graphite. Chips should not be washed with a solvent or treated magnetically because of the risk of a taring the distribution of metal and graphite. A tool with a diameter of 10 mm is suitable for obtaining chips by drilling.

The size range of chips intended for the determination of total carbon should be 1 mm to 2 mm.

When machining is not practicable, the sample can be broken into pieces which are then crushed using a percussion mortar or vibratory grinding mill to obtain a sufficient mass of sample for analysis, of particle size less than 150 μm . This method should only be used in cases where it can be shown that comminution does not lead to contamination of the sample.

6.4.2.2 Methods

For a chilled sample, drill the sample, if practicable, discarding chips obtained from the surface.

For a non-chilled sample, in the case of a cylindrical block, drill a hole transversely at a position one-third along the length of the block. Then drill another hole from the opposite side. Discard chips from one-third of the radial depth in both directions. Continue drilling through the centre of the block to obtain the sample for analysis.

In the case of a test bar, use one of the following methods.

- a) Grind two flats on opposite sides of the bar and drill from one side to the other at a position one-third along the bar.

- b) Turn the test bar using a lathe with a maximum cut of 0,25 mm; do not use a cutting fluid or coolant. Use a radial cut from edge to centre, or face turn a cross-section of the bar; do not confine turning to the surface of the bar. Discard chips obtained from the surface of the bar.

For a non-machinable sample, break pieces from the sample or cut a 3 mm slice or disc from the cross-section near the bottom of a test bar. Crush these pieces using a percussion mortar or vibratory grinding mill to obtain a sufficient mass of sample for analysis of particle size less than 150 μm .

6.4.3 Sample in the form of a solid mass for analysis by a thermal method

In the case of a chilled sample, remove the pin from the sample and break or cut the pin into pieces for use as test portions.

Alternatively, crush the pin in a percussion mortar to provide a sample for analysis of particle size approximately 1 mm to 2 mm. Avoid the production of fine material during crushing.

For a non-chilled sample, use a saw to cut a 3 mm disc or slice from the cross-section of a cylindrical block or test bar and cut pieces of a suitable mass for use as test portions.

Analyse a representative number of test portions to obtain an average value. The mass of a piece selected as a test portion should not be less than approximately 0,3 g.

6.4.4 Sample for analysis by a physical method

In the case of a chilled sample, remove any pins and then use a fixed-head grinder to expose a white iron structure which is representative of the sample. The amount of material to be removed in this way shall be determined for the chemical composition of the particular iron and the conditions of sampling; the thickness of the layer to be removed is normally at least 1 mm.

Air-cooling is recommended during grinding. Grinding can be carried out wet to avoid overheating the sample but the final treatment shall be dry grinding or finishing. Excessive grinding may lead to errors in analysis if the chill region of the sample is exceeded. Chilled samples shall be examined regularly in routine practice to ensure the suitability of the metallurgical structure of the prepared sample for the analysis method.

For a non-chilled sample, use a grinding or finishing machine to remove a layer approximately 1 mm in thickness from the surface of the sample. Air-cooling is recommended during grinding; liquid coolants shall not be used.

For irons which are subject to segregation effects, for example, engineering iron with a high phosphorus content ductile iron with a high silicon content, or malleable iron, prepare the surfaces of two sides of the sample for analysis to obtain an average value.

Overheating of the sample during surface preparation shall be avoided. This can result in surface crazing which will affect the correctness of analysis.

Care is required when preparing the surface of a thin coin-sample. A chuck shall be specially designed to hold the sample securely during grinding operations.

NOTE 6 A fixed-head grinder is preferable to a swing grinder for surface preparation. The swing grinder may not give a flat surface to the sample for analysis.

6.5 Sampling and sample preparation for the determination of oxygen, nitrogen and hydrogen

6.5.1 General

The determination of oxygen, nitrogen and hydrogen is required only to a limited extent in the production of castings. Sampling and sample preparation methods should minimize hydrogen losses and avoid contamination of the sample by oxygen, nitrogen or hydrogen (see 7.5 and 7.6).

6.5.2 Method

It is essential that a sample for the determination of hydrogen should be cooled very rapidly. Remove the sample from the mould immediately after solidification and quench it without delay. A mixture of acetone and solid carbon dioxide in the form of a slurry is suitable for quenching. Store the sample by immersing it in a refrigerant; either liquefied nitrogen or an acetone/solid carbon dioxide slurry is suitable.

For the determination of oxygen and nitrogen, pins broken from a chill-cast sample are normally suitable. Such samples may be obtained from the melt using a spoon and casting the liquid iron, as described in 6.2, into a combination-type book mould to obtain pin-shaped samples of diameter 6 mm to 8 mm. For this purpose, modify the construction of the mould shown in figure 2 by enlarging the three pin-shaped cavities to produce pins of the required diameter.

6.5.3 Preparation of the test portion

Remove all traces of surface oxidation from the pin by turning using a lathe and a tungsten-carbide-tipped tool. Use a separate parting tool to cut the pin transversely, to obtain a test portion of a suitable mass for analysis. Avoid overheating the pin during the preparation of test portions for the determination of hydro-

gen. Cool at frequent intervals using crushed, solid carbon dioxide.

Ensure that there is no delay between the preparation of the test portion and analysis.

7 Liquid steel for steel production

7.1 General

The following methods are applicable to the sampling of liquid steel from furnaces, ladles and other vessels, and from tundishes and moulds during the melting, secondary treatment and casting of the steel.

Special considerations apply to sampling and sample preparation of liquid steel for the determination of oxygen (7.5) and hydrogen (7.6).

7.2 Spoon sampling

7.2.1 Methods

For sampling from a melt, lower the spoon through the slag into the melt and fill with liquid steel. The spoon shall first be immersed in the slag layer to coat it with slag so as to reduce chilling and prevent adhesion of the sample to the spoon. Withdraw the spoon and remove any slag by skimming the surface of the liquid steel in the spoon.

For sampling from a stream, introduce the spoon into the stream from the ladle and fill it with liquid steel. Then withdraw the spoon.

Care shall be taken when introducing the spoon into the stream because of the force of the liquid metal emerging from the nozzle; it may be necessary to reduce the rate of metal flow during sampling.

If necessary, add a measured quantity of deoxidant to the liquid steel in the spoon. When the liquid steel is quiescent (after an interval of up to 10 s), pour without interruption into a one-piece steel mould designed to produce a tapered cylindrical sample. The sample should be approximately 25 mm to 40 mm in diameter at the top and 20 mm to 35 mm in diameter at the base, and 40 mm to 75 mm long.

Remove the sample from the mould and cool in a manner that is designed to prevent cracking. Cool the samples sufficiently slowly to ensure ease of machining.

For sampling stainless steel, a refractory ring placed on a cast iron plate may be used as a mould; the ring should have a wall thickness of 10 mm to 12 mm. The sample is removed from the mould by breaking off the refractory.

NOTE 7 Aluminium wire is frequently used as the deoxidant in spoon sampling, provided that aluminium does not cause interference in the analysis method and that the determination of the aluminium content of the melt is not required. The amount of aluminium added is usually between 0,1 % (m/m) and 0,2 % (m/m). Other deoxidants, such as titanium or zirconium, can be used with similar restrictions.

7.2.2 Maintenance of equipment

It is essential to keep sampling spoons and metal moulds clean and dry. After use, remove any slag and skull and clean the surfaces of the mould with a wire brush.

Moulds should be remachined if the internal surfaces become worn. This avoids the need for additional machining of the sample during surface preparation.

7.3 Probe sampling

7.3.1 General

The main features of the different types of commercially available sampling probes for use with liquid steel are described in annex A.

Probe sampling is influenced by such factors as the angle and depth of immersion of the sampler in the melt, and the time of immersion in the melt. It is essential that these factors be determined for the particular conditions of composition and temperature of the steel involved and thereafter strictly controlled to maintain the standard of quality required for the analysis.

Precautions should be taken to ensure that the operation of probe sampling does not contaminate the sample of liquid steel, particularly when sampling for the determination of elements present in low concentrations. The selection of materials used for construction of the sampling probe, the design of the capping and entrance system, and the method of deoxidation should be such as to minimize the risk of contamination (other than from the deoxidant itself).

7.3.2 Methods

For sampling from deep melts, such as melting furnaces and ladles, quickly immerse a suitable probe sampler through the slag layer into the melt as near as possible to the centre of the melt, at an angle as near as possible to 90°.

For sampling from shallow melts, such as in tundishes, and from the tops of ingot moulds and from continuous casting moulds, introduce the entry tube of a suitable suction sampling probe through the slag or covering powder into the melt. Create a partial vacuum in the sampler for approximately 2 s to fill the mould.

Some tundishes may contain a sufficient depth of liquid metal to permit the use of an immersion sampling probe.

For sampling from a stream, introduce a suitable stream sampling probe into the metal flow from a ladle, at an angle of 45°, at a position as near as possible to the nozzle of the ladle.

Care shall be taken when inserting the probe sampler into the stream; it may be necessary to reduce the rate of metal flow during sampling.

Withdraw the probe sampler from the melt after a predetermined interval of time and break it apart. Allow the probe sample to cool in air to a dull red colour, and then quench in water in a manner that does not cause cracking.

In some cases, probe samples are transported to the laboratory while still hot.

7.4 Preparation of a sample for analysis

7.4.1 Preliminary preparation

Remove any surface oxidation from a sample taken from the melt that may contaminate the sample for analysis during subsequent preparation.

7.4.2 Sample for analysis by a chemical method

In the case of a spoon sample, drill the cylindrical sample at a point one-third from the bottom through to the centre of the sample, discarding the chips obtained from the surface layer of the sample.

Alternatively, remove the bottom third of the cylindrical sample using a cutting-off machine and mill across the whole of the exposed face of the remainder. Heat treatment may be necessary to soften the sample sufficiently for machining.

In the case of a probe sample, obtain chips from the disc section of the sample by drilling or milling as described in 10.4.2.

7.4.3 Sample for analysis by a thermal method

In the case of a probe sample with attached lugs, break off one of the lugs to constitute a test portion.

In the case of a dual-thickness probe sample, punch a slug from the thin section of the disc to constitute a test portion. Heat treatment may be necessary to soften the probe sample sufficiently for ease of punching if the Rockwell hardness of the sample exceeds approximately 25 HRC.

In the case of a disc-and-pin probe sample, cut off a test portion from the pin of a suitable mass for analysis.

In the case of a cylindrical sample, obtain chips by drilling or milling the sample.

Particular care is required in the case of samples for the determination of carbon in low-carbon steels, to prevent contamination during the preparation of the test portion. Use tweezers for all manipulations.

7.4.4 Sample for analysis by a physical method

In the case of a cylindrical sample, cut off the base of the sample, using an abrasive cutting-off disc or cutting-off tool to constitute the sample for analysis, usually 20 mm to 30 mm thick. The surface cut by an abrasive cutting-off disc shall be finished and the surface cut by a cutting-off tool may be finished before analysis.

In the case of a probe sample, remove any lugs or pins, as necessary, and then mill or finish the surface of the disc to expose a surface which is representative of the sample. The amount of material to be removed in this way shall be determined for the chemical composition of the particular iron and the conditions of sampling; the thickness of the layer to be removed normally lies between 1 mm and 2 mm (see A.6 in annex A). In the case of a dual-thickness probe sample, prepare the thick section of the disc.

In the case of samples of leaded steels, equipment used for surface preparation shall be placed in an enclosure and fitted with dust-extraction equipment.

CAUTION — Swarf arising from the surface preparation of leaded-steels, and dust from dust-extraction filter systems, shall be collected and disposed of safely in accordance with local regulations for waste materials containing lead.

7.5 Sampling and sample preparation for the determination of oxygen

7.5.1 Methods of sampling

Methods of sampling liquid steel for the determination of oxygen are based upon the use of commercially available sampling probes. The main features of the different types of probes are described in annex A. Methods of use shall be designed to ensure that sampling operations do not influence the equilibrium between carbon and oxygen in the melt. It is essential to avoid contamination of the sample and to remove all surface oxidation at each stage in sample preparation.

Small appendages to probe samples, such as a pin of diameter less than about 5 mm or a lug, are generally not suitable for preparation as a test portion which is free from surface oxidation. A slug obtained by punching from a dual-thickness probe sample may be satisfactory. For some applications, it may be prefer-

able to obtain a sample of larger mass by using a sampling probe filled by gravity.

7.5.2 Preparation of the test portion

Remove oxidation products from the surface of the probe sample by abrasion in a manner which does not cause overheating.

Cut a slice from the disc of a probe sample. Then cut a cube-shaped test portion from this slice of a mass suitable for analysis.

Place the test portion in a stainless steel holding block or some other device to hold it firm and abrade each surface using a fine-cut file. Use tweezers for all manipulations.

Immerse the test portion in acetone or ethyl alcohol and dry in air or by exposure to a rough vacuum. Analyse immediately; there should be no delay between the preparation of the test portion and analysis.

7.6 Sampling and sample preparation for the determination of hydrogen

7.6.1 General

Methods of sampling liquid steel for the determination of hydrogen are based upon the use of commercial sampling probes. The main features of the different types of probes are described in annex B. Methods of use should be designed to minimize and to control the rapid diffusion of hydrogen from the probe sample which occurs during sampling, storage of the sample, and preparation of the test portion. Losses by diffusion may be large at ambient temperatures, especially from small-diameter samples.

The probe sample should be free from cracks and surface porosity, and from moisture, particularly entrapped water. The condition of the test portion can strongly influence the analytical measurement; methods of analysis may differ in their sensitivity to the presence of water in the sample. If a suction sampling probe is used, the method of operation should be designed to avoid the risk of introduction of moisture into the sample.

The choice of a method of sampling is dependent on the temperature of the melt, the method of analysis and the analytical precision required. These relationships should be investigated to establish a suitable method for a particular steelmaking practice that will give samples of the quality required. Procedural detail should be rigidly adhered to, in order to obtain consistency in the quality of analysis.

It is essential to maintain the probe sample and the test portion at a temperature which is as low as possible at all stages following sampling, and during storage and sample preparation. The sample should be

stored in a refrigerant; either liquefied nitrogen or a mixture of acetone and solid carbon dioxide in the form of a slurry is suitable.

NOTE 8 Such storage is essential for ferritic steels. Diffusion of hydrogen in austenitic steels is slow, but for any particular material, in the absence of experimental evidence, the suggested refrigerant storage should be used.

The probe sample and the test portion should be kept cold when cutting the sample and during the preparation of the test portion. Cooling may be carried out by immersion in ice-cold water or preferably in a refrigerant. Any moisture present on the surface of the test portion after cooling should be removed; the test portion should be immersed in acetone and then dried by exposure for a few seconds to a rough vacuum.

Samples which have been inadequately cooled or stored should be discarded.

Preparation of the surface of the test portion by abrasion should be kept to a minimum, consistent with the need to remove all oxidation products and surface defects. The test portion should be analysed immediately after preparation.

7.6.2 Methods of sampling

A range of commercially-available sampling probes, designed to provide pin-shaped or pencil-shaped samples of varying diameter (see annex B) is available. Use the selected sampling probe in accordance with the manufacturer's instructions.

It is essential that the probe sample should be quenched in cold water and that the water should be stirred vigorously and continuously during quenching. There should be no delay; quenching should take place within an interval not greater than 10 s after taking the sample. A silica sheath used as the sample mould should be removed quickly to allow rapid cooling.

When the sample is sufficiently cooled, immerse the probe sample in a refrigerant for storage and transport it to the laboratory.

If the probe is designed to capture diffusible hydrogen, it should be quenched in order to be cooled sufficiently for handling purposes.

7.6.3 Preparation of the test portion

Cut a test portion of a suitable mass for analysis from the central sections of the probe sample. Cutting shall be carried out in such a manner as to minimize heating the probe sample. Use a copious flow of cooling fluid during cutting or cool the sample at frequent intervals, or use a combination of both methods of cooling.

Prepare the surface of the test portion by filing, grit-blasting or light grinding. If filing is used, abrade the surface by hand with a fine-cut file. If grit-blasting is used, a grit-blasting machine shall be reserved exclusively for this purpose to avoid contamination of the test portion from the grit. If grinding is used, cool the test portion at frequent intervals.

Degrease the test portion by immersion in acetone, dry by exposure to a rough vacuum and analyse immediately. Alternatively, the test portion can be prepared for analysis by immersion in 2-propanol (isopropyl alcohol) and then dried with diethyl ether.

8 Pig-irons

8.1 General

The following methods are applicable to the sampling of iron from the blast furnace which has been cast into masses of a simple shape, known as a pigs, usually in the form of a double lozenge or some other similar shape. The various types of pig-irons are classified in ISO 9147. Other types of iron may be used in the manufacture of cast iron, for example, iron produced in a cupole furnace or an electric melting furnace.

Special care shall be taken to ensure the collection of a representative sample for pig-irons.

8.2 Increment sampling

8.2.1 Number of increments

The number of pigs taken as incremental samples shall be representative of the batch or consignment. In the case of a consignment supplied in bulk, if there is no other agreement between the supplier and purchaser, the minimum number of pigs to be taken from a consignment shall be in accordance with ISO 9147 (see table 1).

Table 1 — Minimum number of pigs to be taken as incremental samples from a consignment of pig-iron

Mass of consignment t	Number of pigs
< 10	9
10 to 20	11
20 to 40	12
40 to 80	14
80 to 160	16
160 to 300	18
300 to 600	21
> 600	24

8.2.2 Methods

During unloading or loading operations, or any other displacement of a consignment, obtain pigs as incremental samples at intervals of time or mass that are approximately equal.

In the case of a consignment supplied in wagons or trucks, the points of sampling shall be disposed in a definite order. For example, from five positions, that is at the centre of the wagon, and at one-sixth of the distance from the corners of the wagons along the two diagonals.

In the case of a stockpile, throw a rope having a certain number of knots onto the pile and take the pigs touched by these knots. Repeat the operation until a sufficient number of pigs is obtained.

Where it is not possible to gain access to the whole of the surface of the stockpile, or where access to the stockpile is unsafe, the points of sampling shall be disposed in a definite order on the surface of the stockpile.

Alternatively, use a mechanical shovel to obtain a number of subsamples from positions in the stockpile selected at random. Then select one pig at random from each subsample.

8.2.3 Consignment of mixed pig-irons

A consignment of pig-iron may contain a number of different batches of pig-iron which may be from different sources. If pigs of different shapes and sizes can be distinguished in the consignment, a visual assessment should be made of the proportions of each type of pig-iron present.

Incremental samples shall then be taken of each type of pig-iron in the consignment to constitute separate subsamples of pigs in order to obtain a weighted average analysis for the consignment.

8.3 Preparation of a sample for analysis

8.3.1 General

If the pigs taken as incremental samples contain remanent magnetism as a result of handling with magnetic grabs, they should be demagnetized by means of a demagnetizing coil to prevent separation of coarse and fine particles during drilling.

Machining of the sample to obtain chips should be carried out by drilling at a low speed (100 r/min to 150 r/min) using a freshly sharpened tool, adjusting the speed and feed to produce chips of uniform size with a minimum amount of fine particles. A drill with a diameter of 12 mm to 14 mm is suitable for obtaining

chips. The drill shall be resharpened at frequent intervals and care taken to avoid overheating both the sample and the tool.

For some types of iron, for example oxygen-blown iron, it may be necessary to use a tungsten-carbide-tipped drill.

Chips should be as solid and compact as possible in order to prevent crumbling and loss of graphite. The particle size range of chips intended for the determination of carbon should be approximately 1 mm to 2 mm.

Milling shall not be employed owing to the high proportion of fines produced.

The prepared sample shall not be washed with a solvent or treated magnetically because of the risk of altering the distribution of metal and graphite.

8.3.2 Sample for analysis by a chemical method

The method of preparation of each of the incremental samples shall be in accordance with one of the following methods.

- a) For machinable iron, clean one face of the pig by grinding at a position midway along the length and width to expose an area of metallic surface of at least 50 mm in diameter. Drill a hole through the cross-section of the pig; cease drilling at a point approximately 5 mm from the opposite face. If necessary, drill another hole parallel to the first hole. (See figures 3a), 3b), 3c) and 3d).]
- b) For non-machinable iron, break the pig at a position midway along its length. Break off pieces from the fractured face, crush these pieces to a particle size of approximately 5 mm and then grind using a vibratory grinding mill to a particle size of less than 150 µm.

Mix equal quantities of the material obtained from each pig. From this mixture, obtain a sample of sufficient mass for analysis by coning and quartering.

Alternatively, analyse the material obtained from each pig separately to obtain an average value for the consignment.

8.3.3 Sample for analysis by a thermal method

8.3.3.1 General

The method of preparation for each of the incremental samples should be in accordance with either 8.3.3.2 or 8.3.3.3, depending upon the condition of the pigs and the type of sample required for analysis.

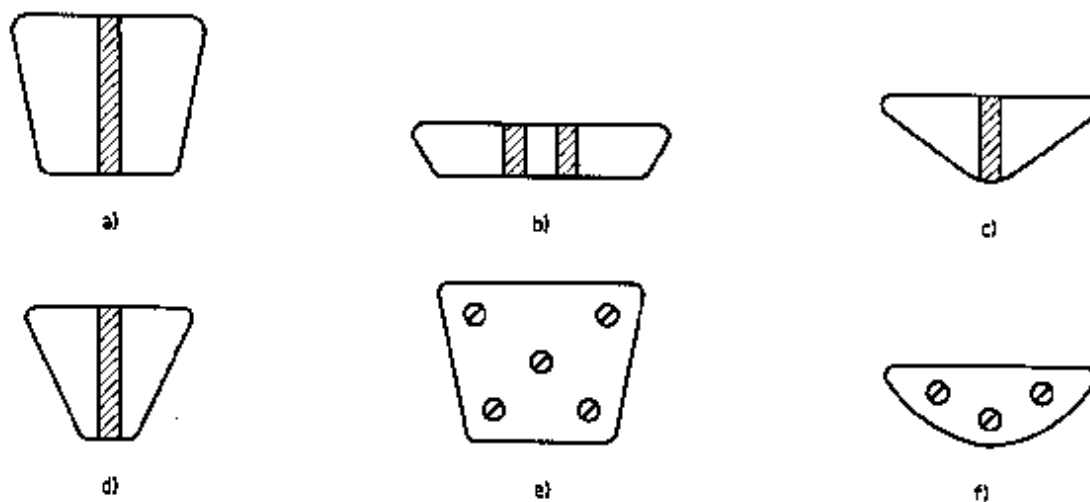

Figure 3 — Sampling positions for pig-irons

8.3.3.2 Sample in the form of chips or fragments

For machinable iron, at the centre of each pig, and on opposite faces, drill a hole 12 mm to 14 mm in diameter. Remove scale and any other impurities around the holes on both sides of the pig. Then drill another hole coaxial with the first hole, 20 mm to 24 mm in diameter, in such a manner that large chips, of size approximately 1 mm to 2 mm, are obtained.

For non-machinable iron, obtain small pieces from the pig as described in 8.3.2 b), and then crush those pieces using a percussion mortar to a particle size of between approximately 1 mm and 2 mm.

Mix equal quantities of the material obtained from each pig. From this mixture, obtain a sample for analysis by coning and quartering.

Alternatively, analyse the material obtained from each pig separately to obtain an average value for the consignment.

8.3.3.3 Sample in the form of a solid mass

Cut a slice, approximately 3 mm thick, from the complete cross-section of the pig at a position midway along its length and clean the edges by grinding. From this slice, cut pieces at positions corresponding to those shown in figures 3e) and 3f) to constitute test portions of a mass suitable for analysis.

Alternatively, saw or break the pig at a position midway along its length. Using a trepanning tool, drill either three or five holes at positions corresponding to those shown in figures 3e) and 3f) to obtain pins of diameter approximately 3 mm. Break the pins into pieces to constitute test portions of a mass suitable for analysis.

Analyse a representative number of the test portions to obtain an average value for each pig.

8.3.4 Sample for analysis by a physical method

Samples obtained from pig-irons are not normally analysed by physical methods of analysis. If it is intended to make use of physical methods of analysis, the method of preparation of the sample shall take account of the structure of the iron and be designed to expose a representative surface for analysis.

Alternatively, it may be possible to prepare the sample in a suitable form by remelting small pieces of the sample (see 4.4.5).

9 Cast-iron products

9.1 General

The location and method of taking a preliminary sample or a sample for analysis from a cast-iron product shall be agreed between the supplier and purchaser according to one of the methods described in 9.2.2, 9.2.3 or 9.2.4.

The sample for analysis can be selected from a test bar or block cast onto the casting for the purpose of mechanical testing.

Special care shall be taken to ensure that a representative sample for analysis is collected from cast-iron products. There may be differences in chemical composition, particularly in the contents of carbon, sulfur, phosphorus, manganese and magnesium, between the selected sample and that of the casting or

castings as a whole. Segregated elements may concentrate towards the upper surfaces of a casting and under cores; these regions should be avoided when selecting a preliminary sample or a sample for analysis. Sectional dimensions and areas of differential heating or cooling require special attention. Careful consideration is necessary in the design of sampling strategies for engineering iron with a high phosphorus content, and malleable and ductile irons. Particular attention is required when sampling grey irons to ensure that the sample for analysis is representative of the chemical composition of the product, especially where segregation is suspected.

9.2 Sampling and sample preparation

9.2.1 General

Sampling and sample preparation shall be in accordance with the grade of iron and type of casting, and the method selected for analysis.

The sample product or preliminary sample shall be cleaned by scratch-brushing, grinding or shot-blasting, to remove adhering particles of sand and to expose areas of metallic surface. It shall be ensured that both the inner and outer surfaces of hollow castings are clean.

9.2.2 Sample for analysis by a chemical method

9.2.2.1 General

Machining of the sample to obtain chips should be carried out by drilling or turning at a low speed (100 r/min to 150 r/min) using a tungsten-carbide tipped tool, adjusting the speed and feed to produce chips of uniform size with a minimum amount of fine particles. Care shall be taken to avoid overheating both the sample and the tool. There is a risk of fracture of the tool when using a carbide-tipped drill, in which case the chips shall be discarded.

Milling shall not be employed owing to the high proportion of fines produced.

Chips should be as solid and compact as possible, with a mass of approximately 10 mg (100 chips per gram), in order to prevent crumbling of graphite. Chips shall not be washed with a solvent or treated magnetically because of the risk of altering the distribution of metal and graphite. A tool with a diameter of 10 mm is suitable for obtaining chips by drilling.

The size range of chips intended for the determination of carbon or nitrogen should be approximately 1 mm to 2 mm.

When machining is not practicable, the sample can be broken into pieces which are then crushed using a percussion mortar or a vibratory grinding mill to obtain a sufficient mass of sample for analysis, of particle

size less than 150 μm . This method should only be used in cases where it can be shown that comminution does not lead to contamination of the sample.

9.2.2.2 Methods

The method of sampling and sample preparation shall be in accordance with the type of cast iron as follows.

- a) For grey irons, obtain chips from the central section of a casting, that is from a region which represents approximately one-third of a complete section of the casting. Do not use chips obtained from the as-cast surface for analysis. Where possible and depending upon the shape of the casting, obtain the chips by drilling the casting at several positions. Mix chips obtained in this way to constitute the sample for analysis.

For a casting of large section, it may be impracticable to drill through the casting. In such a case, the aim should be to drill half-way through the section of the casting.

In the case of a hollow casting such as a pipe, drill completely through the wall of the pipe at each end and in the middle, with the axes of the three drill holes at 120° to each other.

In the case of a large casting, obtain a preliminary sample of diameter 3 mm to 5 mm by using a trepanning tool. Break the sample into small pieces and crush pieces using a percussion mortar or vibratory grinding mill to obtain a sufficient mass of sample for analysis of particle size less than 150 μm .

- b) For malleable irons, the sample for analysis should wherever possible be obtained prior to treatment by annealing.

Annealing causes major segregation and it is essential that a sample taken from a casting that has been annealed represents the full cross-section of a casting. Particular care is required when obtaining a sample from a casting with variable sectional thickness.

If annealed material has to be analysed, remove a complete cross-section by machining, break into pieces and crush in a percussion mortar or disc mill. Separate the coarse and fine fractions using a 150 μm sieve and determine the mass of each fraction. Thoroughly mix each of the fractions separately and weigh proportionate amounts to obtain a representative sample for analysis.

- c) For white irons and alloy irons, it may be possible to obtain the sample for analysis by drilling as described in a).

Where drilling is impracticable, cut thin slices from the sample product or preliminary sample, preferably complete cross-sections, using a saw

or, if necessary, an abrasive cutting disc. If an abrasive cutting disc is used, remove any heat-affected zone.

Break the slices into pieces and crush in a percussion mortar or vibratory grinding mill to obtain a sufficient mass of sample for analysis of particle size less than 150 μm .

NOTE 9 Malleable iron products are particularly susceptible to segregation of manganese sulfide where the manganese to sulfur ratio exceeds 2:1.

9.2.3 Sample in the form of a solid mass for analysis by thermal methods

Cut a thin slice from the sample product or preliminary sample as described in 9.2.2.2 c).

In the case of a large casting, obtain a sample for analysis of diameter 3 mm to 5 mm by using a trepanning tool. Break off pieces from the sample for analysis, or cut using a saw to obtain a number of test portions of suitable mass for analysis. Analyse a representative number of pieces and obtain an average value. The mass of a piece selected as a test portion should not be less than approximately 0,3 g.

9.2.4 Sample for analysis by a physical method

Use a saw or abrasive cutting disc to cut a sample for analysis of suitable size from the sample product or preliminary sample.

Prepare a cut surface by grinding using a fixed-head machine or by finishing, or by a combination of both methods. Air-cooling is recommended to avoid overheating the sample; liquid coolants shall not be used.

Alternatively, the sample may be prepared for analysis by remelting (4.4.5). Break pieces from the complete cross-section of the preliminary sample. Remelt a representative number of these pieces to obtain a sample for analysis.

The method selected for remelting shall produce a chill-cast sample with a white iron structure. Particular attention shall be given to the requirements specified in 4.4.5 concerning partial losses of elements.

NOTES

10 A fixed-head grinder is preferable to a swing grinder for surface preparation. The swing grinder may not give a flat surface to the sample for analysis.

11 Samples obtained from cast iron products which contain free graphite may not be suitable for high-quality analysis when using optical emission or X-ray fluorescence spectrometric methods. In such cases, it is preferable to use other methods of analysis for obtaining suitable samples, as described in 9.2.2 and 9.2.3.

10 Steel products

10.1 General

The location and method of selecting a preliminary sample or a sample for analysis from a sample product should be agreed between the supplier and purchaser according to one of the methods described in 10.2 and 10.3.

The preliminary sample or sample for analysis can be taken from the sample product at the location indicated in the product standard for the selection of material for mechanical testing, or as specified in ISO 377. See also 4.3.2.

Special considerations apply to the sampling and sample preparation of leaded steel products (10.5), and of steel products for the determination of oxygen (10.6) and hydrogen (10.7).

10.2 Selection of a preliminary sample or a sample for analysis from a cast product

From a cast product of large section, obtain a sample for analysis in the form of chips at a point midway between the outside and centre of the section, by drilling parallel to the axis. If this is not practicable, obtain the sample for analysis by drilling the section from the side and collecting chips that represent the part of the section midway between the outside and centre.

Alternatively, and where a sample is required in the form of a solid mass, cut a preliminary sample from the product by machining or by using a cutting torch at the half or quarter of its cross-section.

10.3 Selection of a preliminary sample or a sample for analysis from a wrought product

10.3.1 General

For a rolled product, the process of selecting a preliminary sample shall be carried out on a section of the product perpendicular to the direction of rolling and at one end of the product.

Methods of obtaining a sample for analysis in the form of a solid mass or chips are described in 10.3.2 by reference to products of differing cross-sections.

10.3.2 Sections

Cut a preliminary sample from the sample product transversely in the form of a slice.

To obtain a sample for analysis in the form of a solid mass, cut a piece from the preliminary sample of a suitable size for the analysis method.

To obtain a sample for analysis in the form of chips, mill the whole of the cross-sectional area of the preliminary sample. Where milling is impracticable, drilling may be employed but is not recommended for rimming steels. The most suitable drilling position depends on the shape of the section, as follows.

- For a section of symmetrical shape, for example a billet, a round, a slab, obtain chips by drilling a cross-sectional cut face in a direction parallel to the longitudinal axis at points midway between the centre and edges [see figures 4a) and 4b)].
- For a section of complex shape, for example, an angle, a tee, a channel, a beam, obtain chips by

drilling at points indicated in figures 4c), 4d), 4e), 4f) and 4g) leaving a clearance of at least 1 mm round the drill.

- For a rail, obtain chips by drilling a hole, of diameter 20 mm to 25 mm, in the head of the rail at a position halfway between the centreline and edge of the rail [see figures 4h) and 4i)].

Where drilling into the end or cut face of the section is impracticable, chips may be obtained by drilling inwards from the surface perpendicular to the main axis.

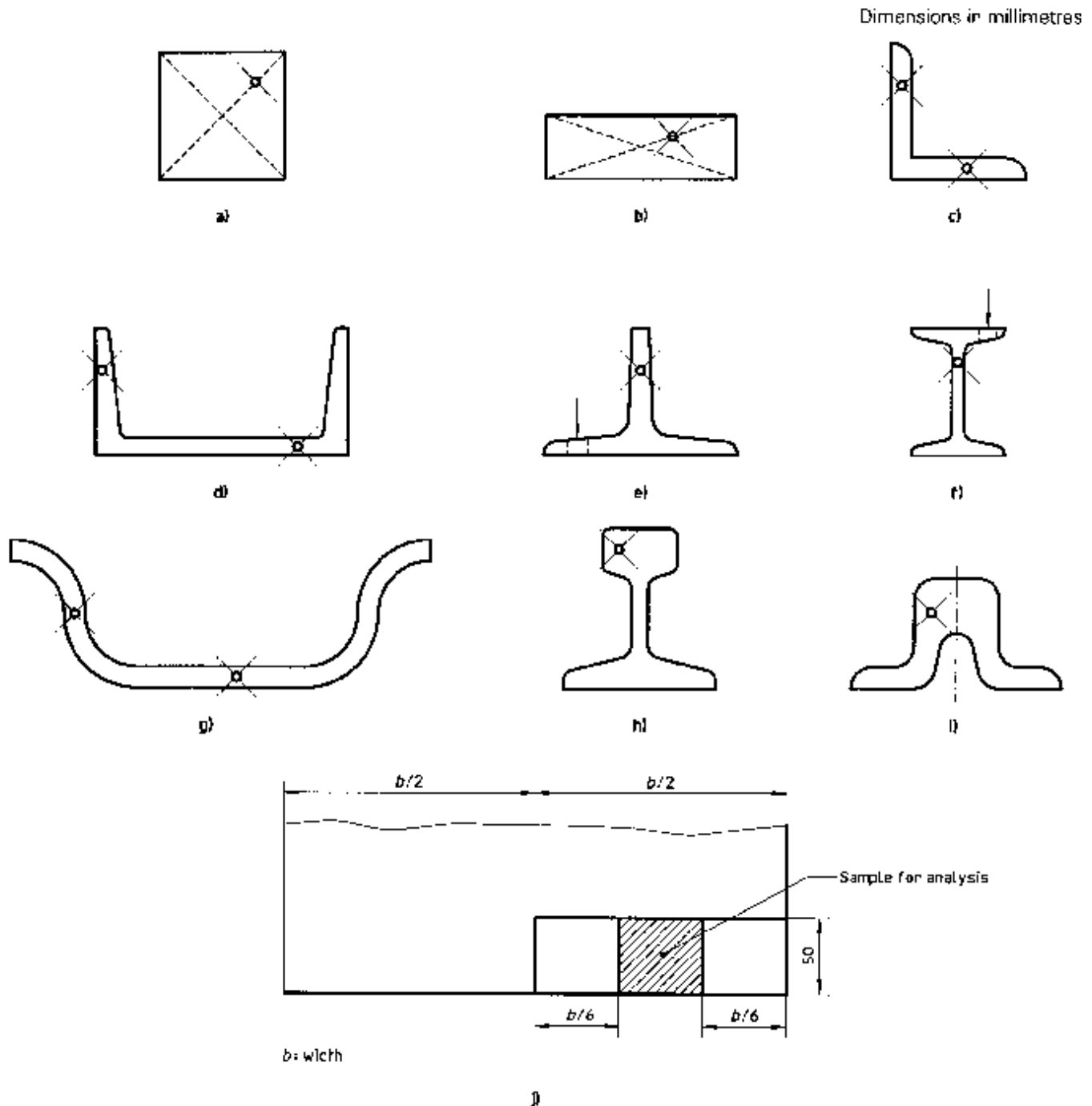

Figure 4 — Sampling positions for steel sections

10.3.3 Plates or slabs

Cut a preliminary sample, of a suitable size for the preparation of a sample for analysis in the form of a solid mass or chips, from a point midway between the centreline and the outer edge of the plate. [In the example shown in figure 4j), the preliminary sample is 50 mm wide.] Where this is not practicable, the sample shall be taken from a position agreed between the supplier and purchaser as being representative of the plate composition.

10.3.4 Light sections, bars, rods, sheets, strips and wires

Where the sample product is of sufficient cross-sectional area, cut a slice transversely to constitute the preliminary sample and obtain a sample for analysis as described in 10.3.2.

Where the sample product is of insufficient cross-section for machining, for example, a thin gauge sheet, a strip, a wire, mill over the combined transverse-sections obtained either by bundling the material after cutting into suitable lengths, or by folding.

Where the sample sheet or strip is thin but is wide enough, mill over the combined longitudinal or transverse sections in a zone midway between the centreline and the outer edge of a sheet or strip [in the example shown in figure 4j)] obtained in the same way.

For a sheet or a strip where the rolling direction is unknown, take lengths of strip in two directions at right angles, and combine the resulting samples.

10.3.5 Tubes and pipes

Sampling may be in accordance with one of the following methods.

- Cut a preliminary sample at a position 90° from the weld in a welded product.
- Cut across the tube and turn or mill across the cut face to obtain a sample for analysis in the form of chips. Tubes with a small cross-section may be flattened before milling.
- Drill through the wall of the tube or pipe, at several positions around its circumference, to obtain a sample for analysis in the form of chips.

10.4 Preparation of a sample for analysis

10.4.1 General

Methods for the sample preparation of steel products shall be in accordance with the general requirements specified in 4.4. Special requirements are considered in the following.

10.4.2 Sample for analysis in the form of chips

Chips obtained by machining shall be sufficiently small to avoid or minimize the need for subsequent fragmentation to prepare the sample for analysis. The size of the chips should be such that the mass of individual chips is approximately 10 mg (100 chips per gram) for unalloyed and low-alloy steels, and approximately 2,5 mg (400 chips per gram) for high-alloy steels.

If the chips are not small enough for analysis, crush them in a percussion mortar.

Machining shall be carried out in such a manner as to avoid the production of fine material. In the case of a sample for analysis which does contain fine powder, that is particles of size less than approximately 50 µm (500 µm for graphite carbon, sulfur and other elements which tend to segregate depending on chip size), separate the coarse from the fine particles and determine the mass of each size fraction. Weigh proportionate parts of each fraction to obtain a representative sample for analysis.

In the case of a sample for analysis for the determination of nitrogen, contamination of the chips may occur during machining caused by atmospheric nitrogenation of fine particles. Obtain the sample for analysis by machining the preliminary sample in such a manner as to avoid, as far as possible, the production of particles of a size less than approximately 50 µm and preferably under an argon atmosphere. Store the chips in an airtight container.

In the case of a sample for analysis to be used for the determination of carbon where it is present in very small amounts, for example, in interstitial-free steels, the chips may be subject to contamination from carbonaceous materials present in the atmosphere or from other sources. The chips shall be stored in an airtight container or preferably an inert atmosphere. It is preferable to remove surface carbon, for example by preheating just before the determination, or to determine the surface and internal carbon separately, for example by resolved signals. Alternatively, a test portion in a solid form may be selected, such as a slug obtained by punching.

10.4.3 Sample for analysis in the form of a solid mass

In the case of products of thin section, such as strips or sheets, test portions for analysis by thermal methods can be produced by nibbling small pieces from the edge of the product. Alternatively, slugs of thickness 4 mm to 6 mm can be obtained by punching.

In the case of sample products with a thickness of approximately 1,5 mm or less, it is necessary to reduce the local heating that occurs when an electrical discharge is produced when using an optical emission spectrometric method. For example, the edges of the sample for analysis can be electrically welded to a

small block of steel or the sample can be embedded, for example in tin, leaving one surface exposed.

10.5 Sampling of leaded steel

Care shall be taken to minimize the creation of dust particles during all sampling and sample preparation operations.

Select a preliminary sample from the sample product by sawing.

Chips shall be obtained by milling at a low speed to avoid overheating the sample and the creation of dust.

Equipment used for the surface preparation of a sample for analysis by a physical method shall be enclosed and fitted with dust-extraction equipment.

CAUTION — Swarf arising from machining and surface preparation of leaded steels, and dust from dust-extraction filter systems, shall be collected and disposed of safely in accordance with local regulations for waste materials containing lead.

10.6 Sampling and sample preparation for the determination of oxygen

10.6.1 General

It is essential to avoid contamination of the sample and to remove any surface oxidation at each stage of sampling and sample preparation.

Do not allow the fingers to come into contact with the test portion; use tweezers for manipulation. In the case of steels with very low oxygen contents, machining of the test portion should be carried out under the protection of an inert gas.

10.6.2 Methods of sampling

Sampling should be in accordance with one of the methods described below.

- a) Cut a suitably shaped preliminary sample using a mechanical saw. The sample can, for example, be in the form of a small plate or disc. Using a hand saw, cut a test portion from this sample of a mass that is suitable for analysis.
- b) Cut a preliminary sample in the form of a slice of thickness 3 mm to 4 mm. Finish the surfaces of the sample using 60 grit abrasive paper made of silicon carbide and then abrade by using a burr, that is a rotary tool with cutting teeth, at a speed of approximately 30 000 r/min.

The condition of the surfaces of the sample after preparation should be smooth, metallically bright and free from defects.

Punch a slug from the sample of a suitable mass for analysis to constitute a test portion using a punch of diameter 4 mm to 6 mm. Carry out the punching operation in such a manner that the test portion falls into a glass container which is purged with argon or nitrogen and can be closed with a cap or stopper.

- c) Cut a rectangular preliminary sample, approximately 10 mm wide and 100 mm long. Turn the sample using a lathe at a speed of approximately 1 000 r/min to obtain a diameter of approximately 7 mm; continue turning at a controlled feed rate of approximately 0,1 mm to 0,15 mm per revolution at a speed of 800 r/min to 1 000 r/min to reduce the diameter of the sample to 6 mm. The condition of the surfaces of the sample after preparation shall be smooth, metallically bright and free from defects. Cooling lubricants shall not be used during the final stage of the machining process.

Using a hand saw, cut a test portion from the turned sample of a mass that is suitable for analysis.

10.6.3 Preparation of a test portion

In the case of 10.6.2 b), if the test portion and preliminary sample have no oxidation, the test portion can be used directly after it is picked up from the punching machine (after storage of limited duration in a glass flask). In the case of 10.6.2 a) and c), place the test portion on a stainless steel holding block or some other device to hold the test portion firm; abrade the surfaces using a fine-cut file or a burr [see 10.6.2 b)].

In the case of a test portion obtained using the method described in 10.6.2 c), the cylindrical surface of the test portion should be sufficiently smooth to dispense with the need for filing. However, each of the two end faces should be prepared using a file. Immerse the test portion in acetone and dry in air or by exposure to a rough vacuum; analyse immediately.

There should be no delay between the preparation of the test portion and analysis.

10.7 Sampling and sample preparation for the determination of hydrogen

10.7.1 General

Methods should be designed to minimize and control the rapid diffusion of hydrogen from the sample which occurs during sampling, storage of the sample, and preparation of the test portion. The sample should be free from cracks, surface porosity and moisture. The condition of the test portion can strongly influence the analytical measurement; methods of analysis may differ in their sensitivity to the presence of water.

Procedural detail should be rigidly adherent to in order to obtain consistency in the quality of analysis.

Losses of hydrogen from the sample by diffusion may be large at ambient temperatures, especially from samples with thin cross-sections. It is essential to maintain the preliminary sample, sample for analysis and test portion at a temperature which is as low as possible at all stages during sampling, storage and sample preparation. The sample for analysis should be stored in a refrigerant; either liquefied nitrogen or a mixture of acetone and solid carbon dioxide in the form of a slurry is suitable.

The sample and the test portion should be kept cold when cutting the sample and during preparation of the test portion. A copious flow of cooling fluid should be used during all machining operations or the sample and test portion should be cooled at frequent intervals, or a combination of both methods should be used. Cooling may be carried out by immersion in ice-cold water or preferably in a refrigerant. Samples of large section should be packed with solid carbon dioxide in a manner which ensures the maintenance of good thermal contact with the sample. During intervals between machining, rough-cut pieces should be returned to storage in a refrigerant.

Any moisture present on the surface of the test portion after cooling should be removed. The test portion should be immersed in acetone and then dried by exposure to a rough vacuum for a few seconds.

Samples which have been inadequately cooled or stored should be discarded.

Preparation of the surface of the test portion by abrading should be kept to a minimum, consistent with the need to remove oxidation products and surface defects. The test portion should be analysed immediately after preparation.

10.7.2 Methods of sampling

According to the geometric form of a piece or product, use suitable machining tools to prepare the initial sample by turning, milling, sawing, slicing and trepanning etc.

From a cast product or forging, obtain a sample for analysis of a suitable size in the centred part where hydrogen is dense.

From a long wrought product, using a saw or an abrasive cutting disc, obtain a preliminary sample at a position midway between the product centreline and the edge, and at a distance from the end of at least half the cross-section. From the preliminary sample, cut a piece of a size suitable for turning using a lathe in order to obtain a sample for analysis.

Store the sample for analysis in a refrigerant.

10.7.3 Preparation of a test portion

From the sample for analysis, cut a test portion of a suitable mass in such a manner as to minimize heating the sample. Cool the sample at frequent intervals.

Prepare the surface of the test portion by filing, grit-blasting or light grinding. If filing is used, abrade the surface by hand with a fine-cut file. If grit-blasting is used, a grit-blasting machine shall be reserved exclusively for this purpose to avoid contamination of the test portion from grit. If grinding is used, cool the test portion at frequent intervals.

Degrease the test portion by immersion in acetone, dry by exposure for a few seconds to a rough vacuum and analyse immediately. Alternatively, the test portion can be prepared for analysis by immersion in 2-propanol (isopropyl alcohol) and then dried with diethyl ether.

Annex A (informative)

Sampling probes for use with liquid iron and steel

A.1 General

Disposable probes for taking samples from liquid iron and steel consist of a small mould made from pressed steel, ceramic material or silica tubing, and which are mounted in a thick-walled protective cardboard tube.

A range of different types of sampling probe is available commercially. The main features are described in A.2 to A.4 with examples shown in figures A.1 to A.6.

The dimensions given in this annex are indicative only.

A.2 Immersion sampling probes

A.2.1 Immersion probes can be inserted into the melt either by hand or by mechanical means using a lance of steel piping fitted into the cardboard tube or attached directly to the probe assembly. Immersion times vary depending on the design of the probe and the conditions of sampling, in particular the temperature of the melt, but normally lie between 3 s and 8 s.

The lance is constructed so that air from the mould cavity and gases produced during the combustion of cardboard can easily escape. A handlebar is incorporated for controlling the lance during immersion and withdrawal.

When sampling from ladles and secondary treatment vessels, a mechanical system can be used to lower and raise the lance.

Some types of probe combine a thermocouple in a silica tube adjacent to the sample chamber for the measurement of temperature. Where a measurement substance is used in a basic oxygen converter furnace, a mould assembly can be incorporated with the measurement sensors in the substance to obtain a sample for laboratory analysis.

A.2.2 Probes in which the sample chamber is filled by ferrostatic pressure consist of a steel split mould held in a cardboard tube by a collar of refractory material. The mould has a bottom-entry silica tube with a protective cap of thin steel to prevent ingress of slag and any other contaminant. Cardboard tubes, which

vary in length from 200 mm to 1 600 mm or longer, may be partially coated with refractory material to minimize splashing during immersion.

This type of probe is mainly used to obtain samples from liquid steel in furnaces and ladles; two different designs are shown in figure A.1.

A.2.3 The samples obtained by using immersion probes filled by ferrostatic pressure can differ in configuration the following three main types are distinguished.

- a) Disc-and-pin probe samples exemplified in figure A.2a); the disc is suitable for analysis by a physical method and the pin may be used, if required, for analysis by a thermal method. The disc may be oval, circular or some other similar shape.
- b) Disc-and-pin probe samples with a number of lugs attached to the disc; the lugs have a mass of 0,5 g or 1 g and may be easily broken off from the disc and can be used, if required, as test portions in thermal methods of analysis.
- c) Dual thickness probe samples exemplified in figure A.2b), in which part of the disc is reduced in thickness and is suitable for the punching out of slugs. The slugs are 4 mm to 6 mm in diameter and are used as test portions in thermal methods of analysis. The thicker section of the disc of a dual-thickness probe sample is used for analysis by physical methods. A probe sample with a Rockwell hardness of greater than approximately 25 HRC may require heat treatment before punching.

A.2.4 Probes of the type shown in figure A.3, in which the sample chamber is filled by gravity, consist of a two-piece or four-piece steel cylindrical mould which is contained in a refractory assembly and attached to a cardboard tube.

The mould has a side entrance port which is protected in some way to prevent ingress of slag. The assembly may be sleeved with refractory to minimize splashing during immersion. The overall length of the assembly and cardboard tube is 400 mm to 800 mm. Immersion times are usually 2 s or 3 s.

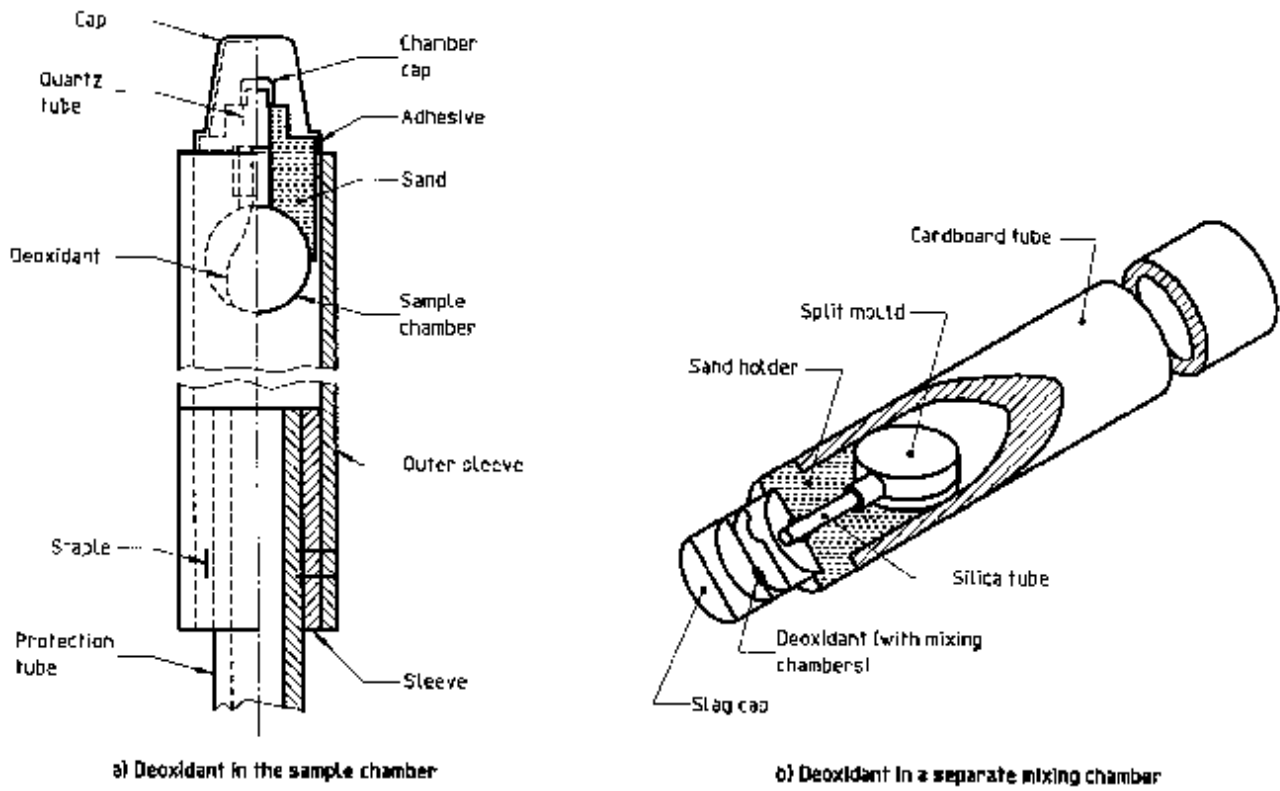

Figure A.1 — Examples of immersion sampling probes filled by ferrostatic pressure

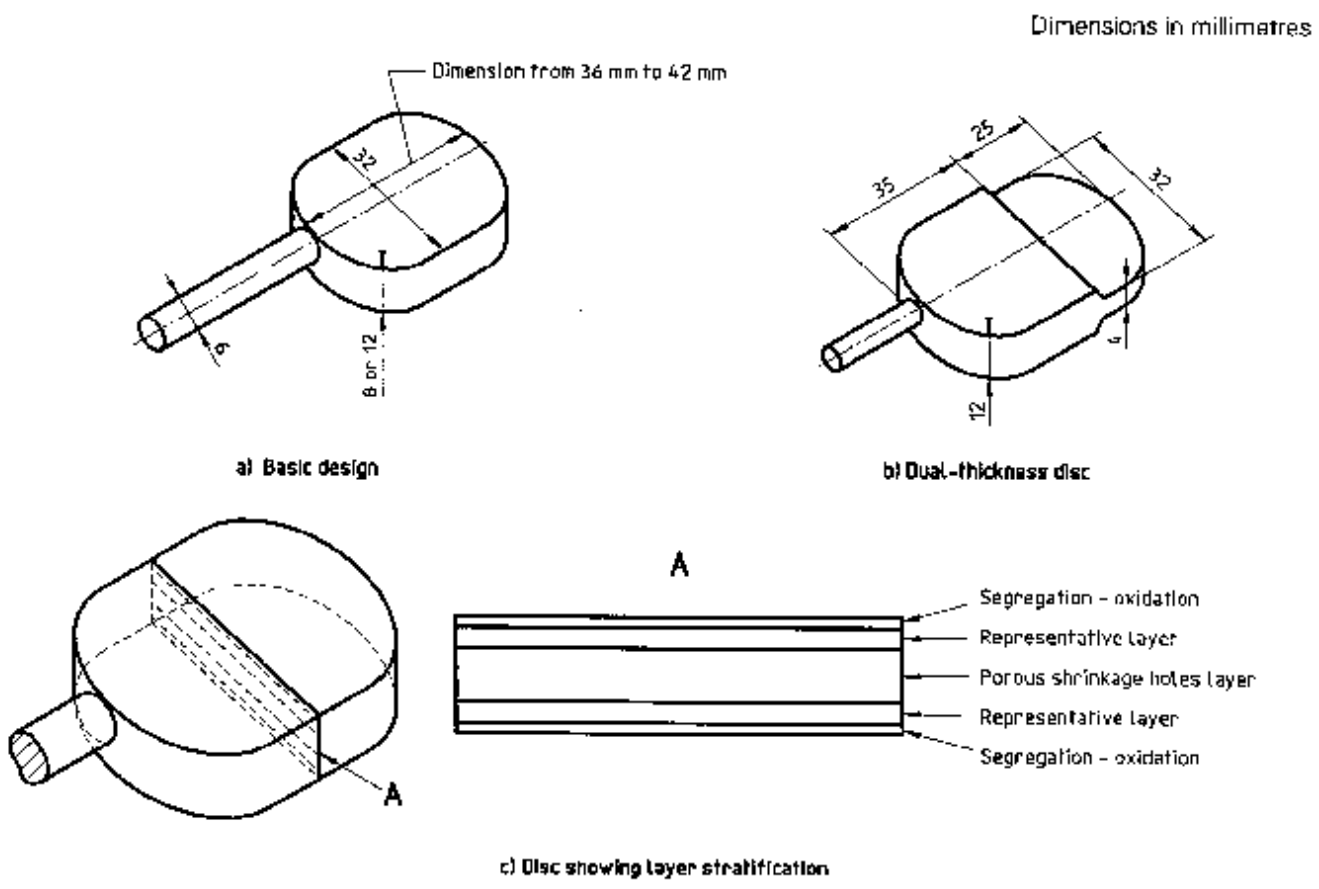

Figure A.2 — Examples of disc-and-pin samples

This type of probe is used in situations where the disc-and-pin type of sample is not satisfactory for analysis. It is used to obtain samples from liquid iron and steel in ladles, and from liquid steel in ingot moulds and continuous casting tundishes. The sample is typically 30 mm in diameter and 70 mm long.

A.2.5 Probes of a special design are used to obtain samples from liquid iron in the blast-furnace runner, and from the torpedo car and transfer ladle. These probes incorporate chill-plates of varying thickness to ensure that the liquid iron of the sample is chilled very rapidly. Two different types are described in a) and b).

a) A variant of the probe filled by ferrostatic pressure (A.2.2) with a design based on the use of either a thick-walled, steel split-mould or steel chill-plates, to provide a disc-and-pin sample with a number of lugs attached to the disc.

b) A probe designed to eliminate risk of drainage of liquid iron when sampling very fluid melts. The side-entry mould has one or more steel chill-plates and is held in a body of sand attached to a cardboard tube.

This type of probe can combine a separate or linked pin-shaped mould. The sample is typically 35 mm in diameter with a thickness varying from 4 mm to 12 mm depending on the metallurgical structure required. The optional pin sample is 6 mm in diameter and 45 mm long.

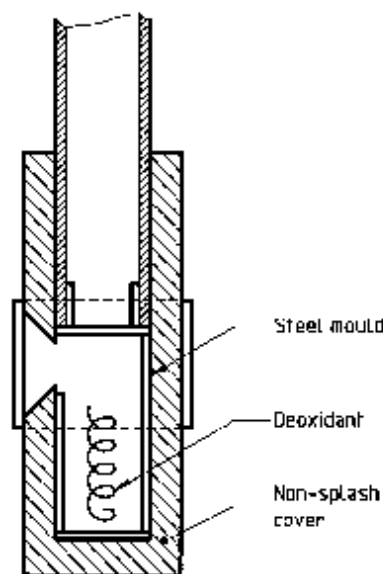

Figure A.3 — Example of an immersion sampling probe filled by gravity

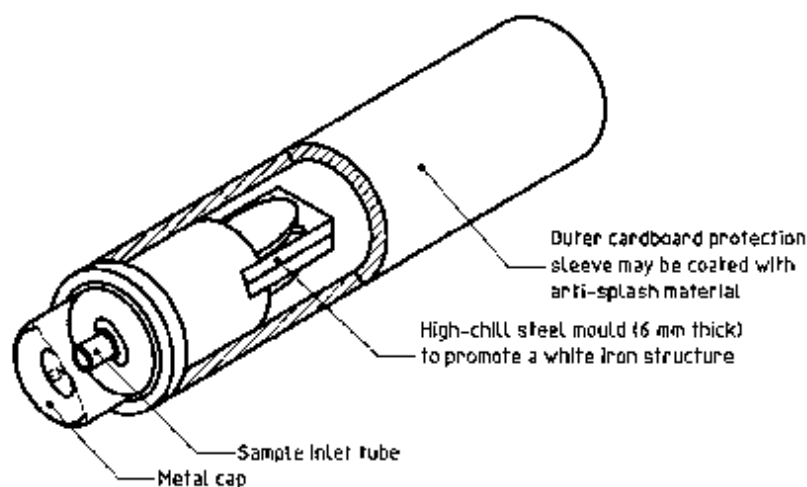

Figure A.4 — Example of an immersion probe used for sampling liquid iron from a blast furnace

A.2.6 Specially designed probes are used to obtain samples from liquid steel in a vacuum induction furnace.

In one example, the sampling mechanism in the form of tube made from a refractory material is located in the furnace charging system and suspended on a wire rope to permit vertical access to the melt by gravitational means. The sample is cylindrical in shape and 35 mm in diameter.

A.2.7 Measurement sensor assemblies used with substances in basic oxygen steelmaking may incorporate moulds for obtaining samples from liquid steel. Moulds of the type described in A.2.2 may be used both in the case of a substance used during oxygen blowing (in-blow operation) and when oxygen is not being blown (end-blow operation). In the case of in-blow operation, a mould of different design can be used to obtain a sample of a rectangular shape, 40 mm x 30 mm and 20 mm thick.

A typical assembly, shown in figure A.5, includes sensors for the measurement of liquidus arrest, temperature and oxygen potential, and incorporates a rectangular mould with a side entry used to obtain a sample during the measurement process.

A.3 Stream-sampling probes

Probes of the type shown in figure A.6a) consist of a steel split-mould with an exposed entry tube of silica held by a plug in a cardboard tube of length 100 mm to 225 mm. Samples are of the disc-and-pin type.

Different designs of mould are used for the sampling of liquid iron.

Lances for stream-sampling probes are designed so that the probe can be positioned in the metal stream at an angle of 45°; some means of supporting the lance may be provided. The sampling time is usually 2 s.

This type of probe is used to obtain samples from liquid iron and steel flowing from ladles.

A.4 Suction sampling probes

Probes of the type shown in figure A.6b) consist of a steel split-mould held in position by a plug in a cardboard tube, about 125 mm in length. The mould has an exposed entry tube of silica with a protective cap to prevent ingress of slag or casting powder. Air is removed from the mould to create a partial vacuum by using a hand-operated pump or a compressed-air venturi pump. The sampling time is usually 2 s.

This type of probe is used to obtain samples from liquid steel in small furnaces, ingot moulds, continuous-casting moulds and tundishes. Samples are of the disc-and-pin type.

A.5 Deoxidation systems for sampling probes

Probes used for the sampling of liquid steel which is oxidized and effervescent contain a deoxidant, usually in the form of wire or a pellet inserted in the probe in such a manner that it becomes uniformly dispersed in the liquid steel. Various methods are used to incorporate the deoxidant in the probe, for example:

- deoxidant in the sample chamber itself, as shown in figures A.1a) and A.3;
- deoxidant in the entry tube to the sample chamber;
- deoxidant in a separate chamber; the deoxidant and liquid steel are thoroughly mixed before the steel enters the sample chamber, as shown in figure A.1b); some probes have a second mixing chamber.

Aluminium, zirconium or titanium are commonly used as deoxidants dependent upon the type of melt and the analytical requirements.

A.6 Quality of sample

A.6.1 Apart from the presence of defects and oxides on the surfaces of the disc sample, the surface layers of the disc may be subject to segregation and the central portion may be porous and subject to shrinkage or other thermal effects as shown in figure A.2c). Special care is necessary to ensure that procedures for preparing the surface of the disc for analysis by physical methods expose a layer of metal that is representative of the chemical composition of the sample.

It is usually necessary to remove a layer of 1 mm to 2 mm from the surface of a disc sample obtained from liquid steel, to expose a part of the sample that is suitable for the physical analysis method selected.

A.6.2 The amount of material removed from the surface of chill samples taken from liquid iron is determined by the metallurgical structure of the sample, which may vary through the thickness of the disc. The type of sampling probe used and the method of preparing the disc sample should be selected to provide a surface structure of either white or grey iron in accordance with the requirements of the analysis method.

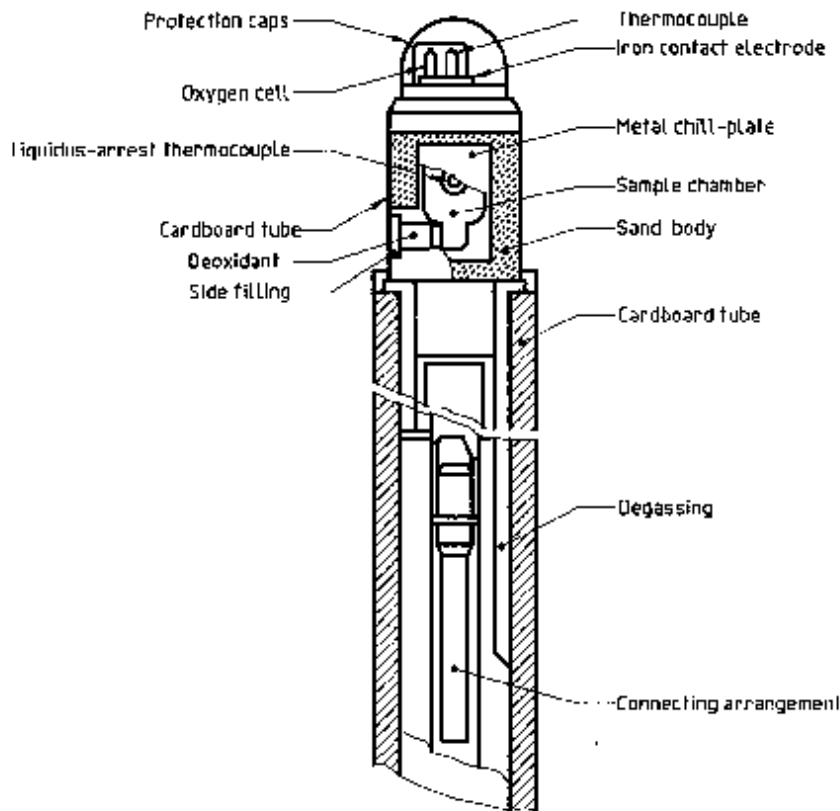

Figure A.5 — Example of a substance probe assembly showing the sample chamber

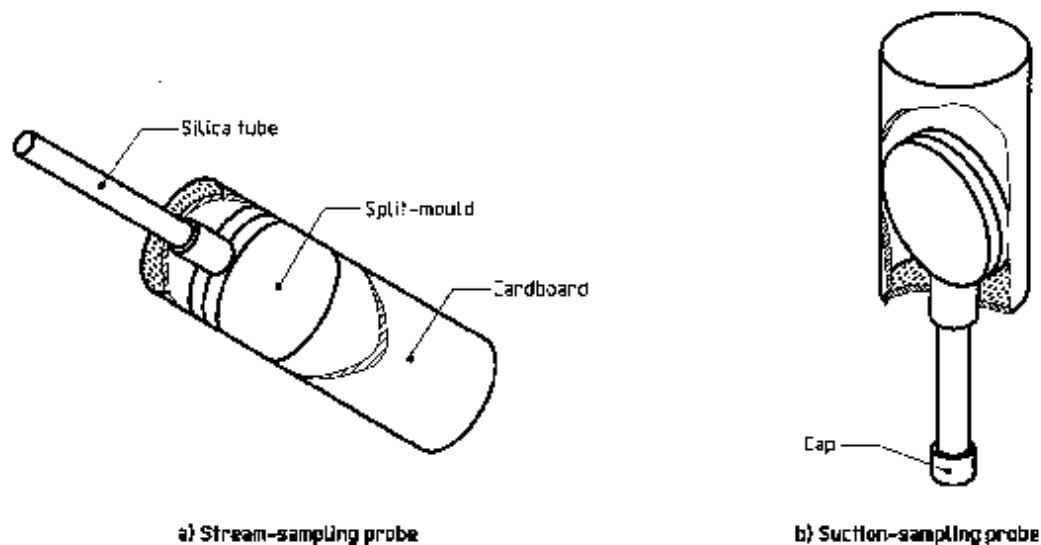

Figure A.6 — Examples of stream-sampling and suction-sampling probes

In the case of a disc sample obtained from liquid iron, it is usually necessary to remove a layer, of thickness approximately 0,5 mm to 1 mm, from the surface of the disc sample.

A.6.3 In routine practice, probe samples should be examined regularly to ensure the suitability of the prepared sample for the analysis method.

Annex B (informative)

Sampling probes for use with liquid steel for the determination of hydrogen

B.1 General

Disposable probes for taking samples from liquid steel for the determination of hydrogen usually consist of a mould made from pressed steel or silica tubing mounted in a thick-walled protective cardboard tube.

Probes are designed to obtain a pin-shaped or pencil-shaped sample, 7 mm to 12 mm in diameter and 75 mm to 150 mm long, from liquid steel in ladles, ingot moulds, and continuous-casting tundishes and moulds.

Several types of sampling probes are available commercially, the main features of which are described in B.2 and B.3 with examples shown in figure B.1.

The dimensions given in this annex are indicative only.

B.2 Immersion sampling probes

Two types of probes for immersion sampling may be distinguished.

- a) Probes of the type shown in figure B.1a) consisting of a silica tube, 7 mm to 9 mm in internal diameter, contained in a protective cardboard tube. The top end of the tube is open and the bottom end is capped with aluminium foil to prevent ingress of contaminants. The cardboard tube is 250 mm or 400 mm in length, depending upon the application, and has a refractory anti-splash coating.

This type of probe is used for taking samples from liquid steel at temperatures near to the liquidus point of the steel.

- b) Probes of the type shown in figure B.1b) consisting of an exposed silica tube, 10 mm to 12 mm in internal diameter, held in a cardboard tube. The top end of the tube is open or may be covered with aluminium foil. The tube has a side entrance port covered with aluminium foil. It may contain

aluminium wire as a deoxidant, typically of a mass of approximately 0,1 g.

This type of probe is used in a wide range of applications for taking samples from liquid steel.

B.3 Suction sampling probes

Two basic types of probes for suction sampling may be distinguished.

- a) An evacuated probe of the type shown in figure B.1c) consisting of a steel sleeve and a sample chamber made from high-purity iron with an internal diameter of 4 mm. The probe is mounted in a cardboard tube and sheathed with a heat-resistant material and may have a protective slag cap.

On immersion in the melt, the fusible cap melts and liquid steel is aspirated into the evacuated sample chamber which then closes as the metal solidifies, thus sealing the probe. Hydrogen which diffuses from the sample is captured in the outer evacuated chamber and is measured when the probe is inserted into specially designed analytical equipment and then pierced.

Any residual hydrogen remaining in the sample can be measured separately after removal of the sample together with the sample chamber.

Probes of the type shown in figure B.1c) are made of a pyrex vacuum tube ($< 10^{-2}$ torr). An advantage of this type of sampling probe is that the inside of the probe is protected from pollution until it is filled up.

- b) Probes of the type shown in figure B.1d) consisting of a pressed steel split-mould, 7 mm to 9 mm in internal diameter and 75 mm long, with a silica entry tube. The mould is held in a cardboard tube by a collar. Air is removed from the mould to create a partial vacuum using a compressed air venturi pump.

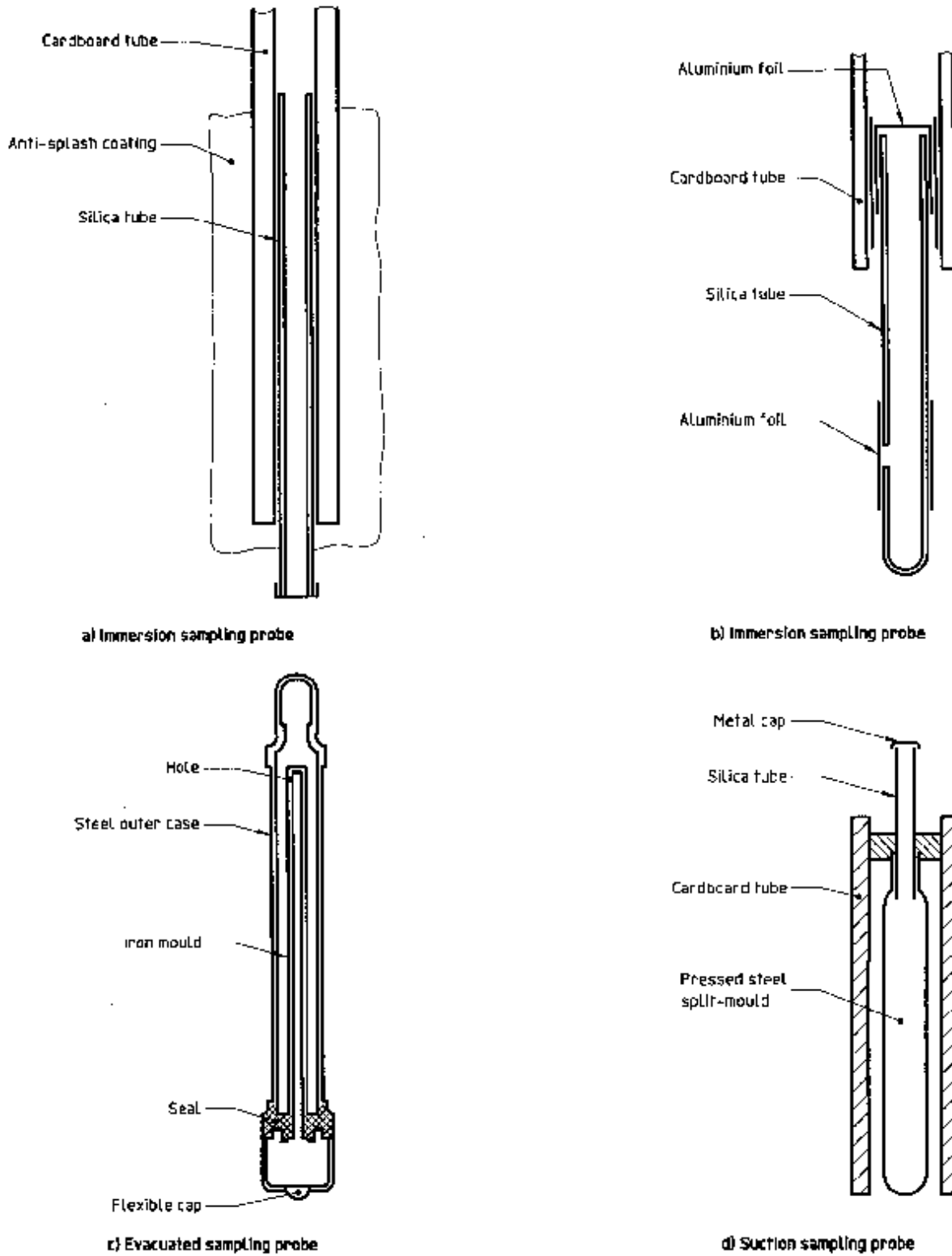

Figure B.1 — Examples of probes used for sampling liquid steel for the determination of hydrogen

ICS 77.080

Descriptors: steels, cast iron, pigs (castings), sampling, specimen preparation, chemical analysis.

Price based on 30 pages
